

# Steamco Valves

**APPLICABLE STANDARDS**  
 BASIC DESIGN: API 602 & ASME B16.34  
 TEST AND INSPECTION: API 598

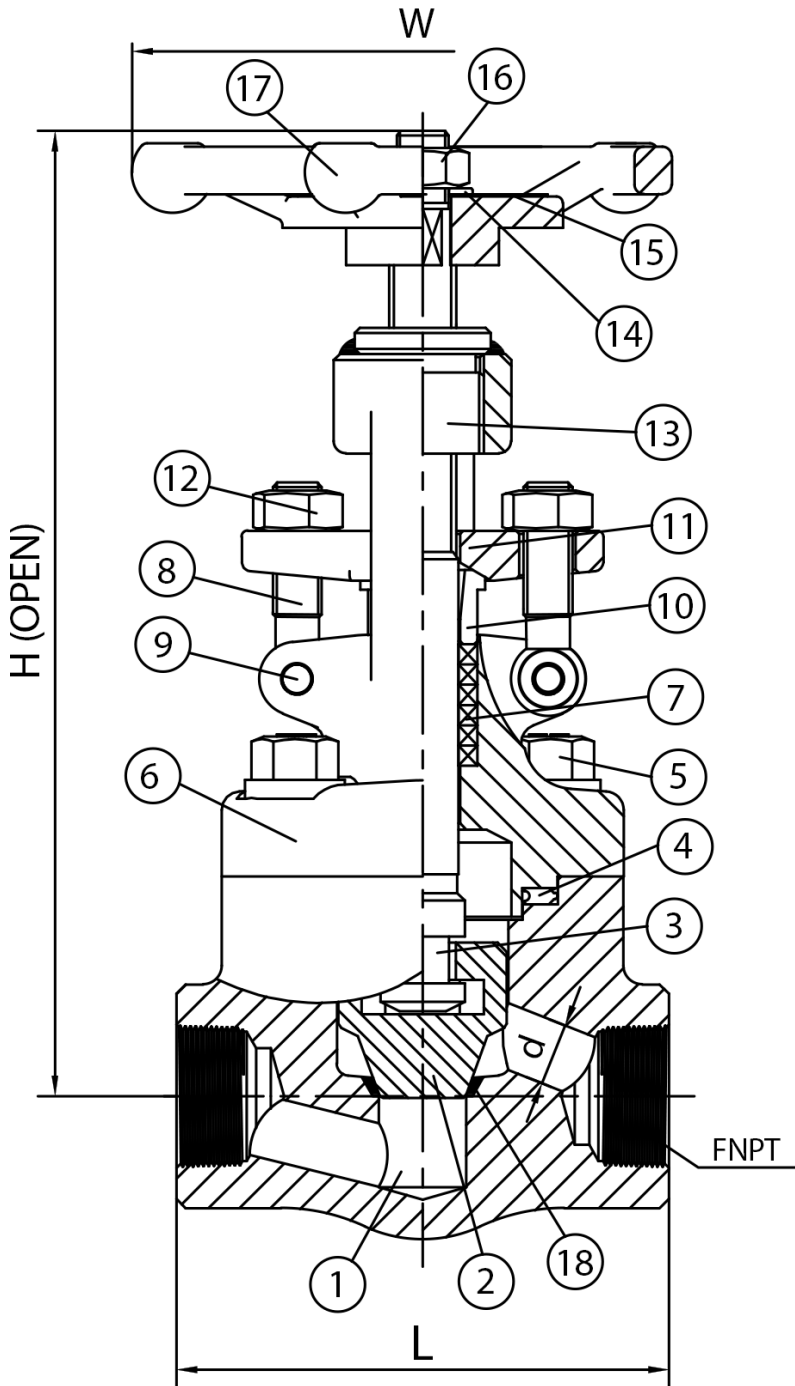

NO.	PART NAME	STANDARD
1	BODY	A105N
2	DISC	A276 420
3	STEM	A276 410
4	GASKET	304 + GRAPHITE
5	BONNET BOLT	A193 B7
6	BONNET	A105N
7	PACKING	GRAPHITE
8	GLAND BOLT	A193 B7
9	GLAND BOLT PIN	A276 304
10	GLAND	A276 420
11	GLAND FLANGE	A105N
12	NUT	A194 2H
13	STEM NUT	A276 410
14	WASHER	A276 410
15	NAMEPLATE	ALUMINUM
16	HAND WHEEL NUT	A194 2H
17	HAND WHEEL	A197
18	INTEGRAL SEAT	A105N + STL

SIZE	DIMENSIONS IN INCHES					Weight (lbs)
	L ±0.06	d <sup>+0.04</sup> / <sub>-0.02</sub>	FNPT	H ±0.2	W ±0.2	
1/2"	3.11	Ø 0.37	1/2"	6.33	3.94	5
3/4"	3.62	Ø 0.49	3/4"	6.33	3.94	8
1"	4.37	Ø 0.69	1"	7.60	4.72	9
1-1/4"	4.72	Ø 0.93	1-1-4"	9.06	6.30	13
1-1/2"	5.98	Ø 1.12	1-1/2"	9.76	6.30	17
2"	6.77	Ø 1.44	2"	11.1	8.66	24

**Steamco Fig. GL800FS8T**

**CLASS 800 THD GLOBE VALVE**