

Steamco Valves

APPLICABLE STANDARDS

BASIC DESIGN: BS 1868

FLANGE DIMENSIONS: ASME B16.5

FACE TO FACE DIMENSIONS: ASME B16.10

WORKING PRESSURE: 300 PSI

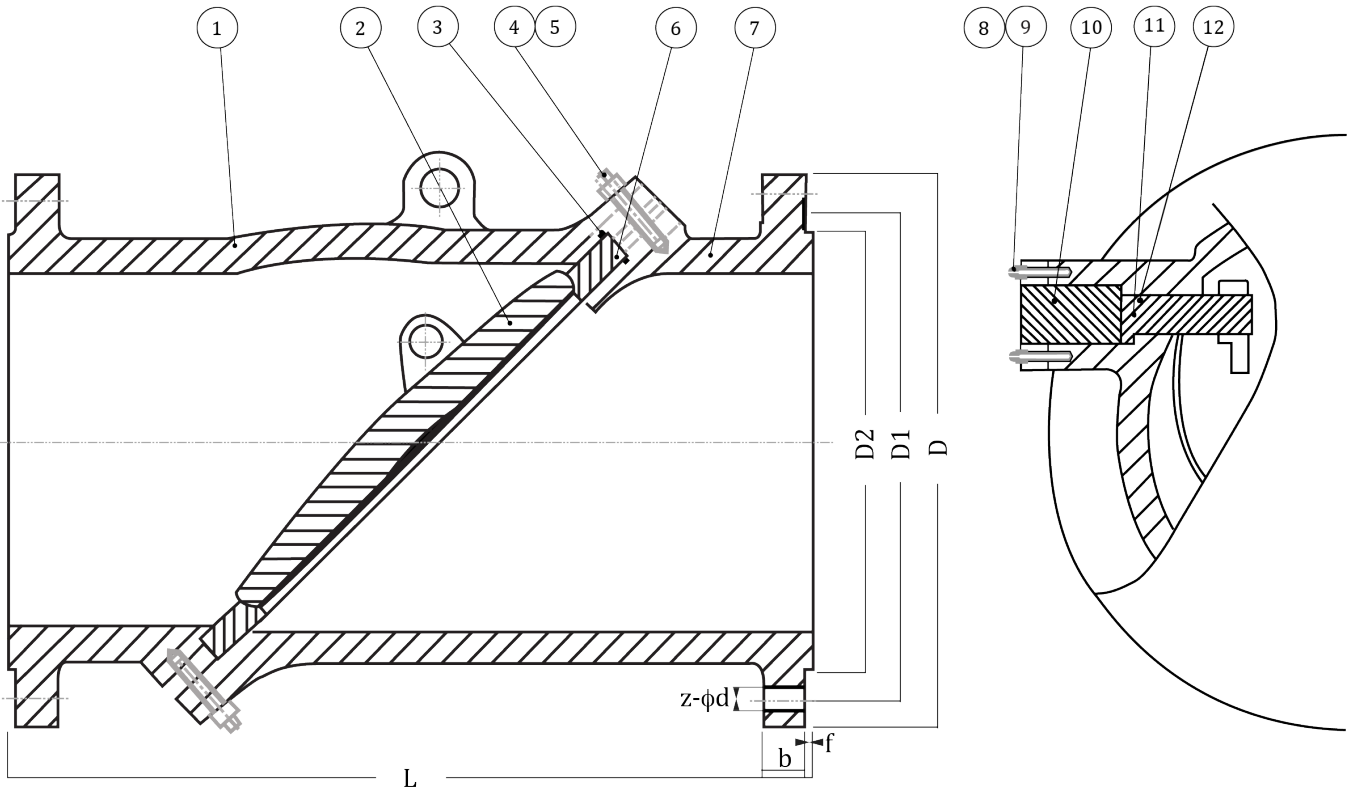

SIZE	L	D	D1	D2	b	z- ϕ d	WEIGHT
2	10.5	6.5	5	3.62	0.91	8 x 3/4	57
3	12.5	8.3	6.63	5	1.14	8 x 7/8	90
4	14	10	7.88	6.19	1.26	8 x 7/8	167
6	17.5	12.5	10.63	8.5	1.46	12 x 7/8	308
8	21	15	13	10.63	1.65	12 x 1	462
10	24.5	17.5	15.25	12.75	1.89	16 x 1-1/8	672
12	28	20.5	17.75	15	2	16 x 1-1/4	1036
14	30	23	20.25	16.25	2.13	20 x 1-1/4	1245
16	33	25.5	22.5	18.5	2.28	20 x 1-3/8	1697
18	36	28	24.75	21	2.4	24 x 1-3/8	2182
20	39	30.5	27	23	2.52	24 x 1-3/8	2645
24	45	36	32	27.25	2.76	24 x 1-5/8	4078

NO.	PART NAME	STANDARD
1	OUTLET BODY	ASTM A216 WCB
2	DISC	ASTM A217 CA15*
3	GASKET	SS304 + GRAPHITE
4	NUT	ASTM A194 2H
5	BOLT	ASTM A193 B7
6	SEAT	ASTM A105 + STL6
7	INLET BODY	ASTM A216 WCB
8	NUT	ASTM A194 2H
9	BOLT	ASTM A193 B7
10	END CAP	ASTM A216 WCB
11	PIN	ASTM A182 F6
12	GASKET	SS304

*WCB FOR 8" AND LARGER

Steamco Fig. TD300CSF8

CLASS 300 FLANGED TILTING CHECK VALVE