

Steamco Valves

APPLICABLE STANDARDS
 BASIC DESIGN: API 602 & ASME B16.34
 TEST AND INSPECTION: API 598

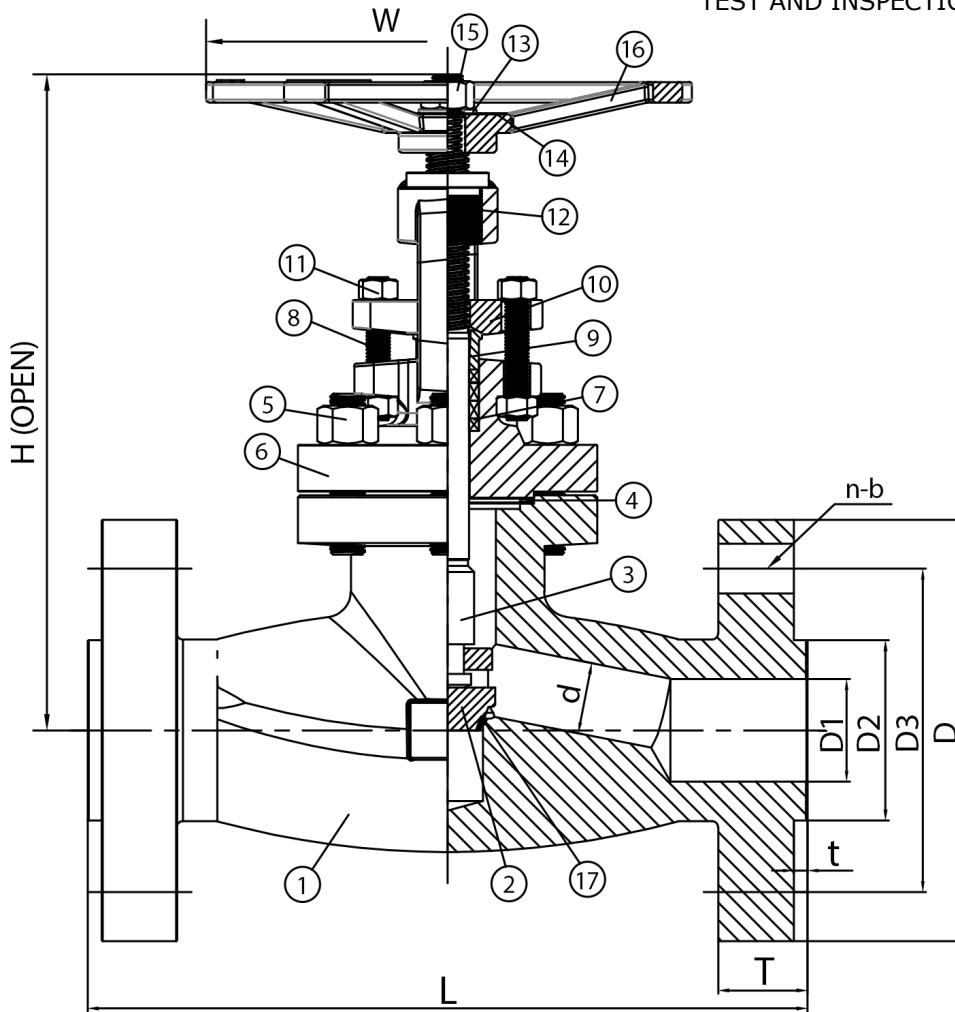

NO.	PART NAME	STANDARD
1	BODY	A182-F11
2	DISC	A276 410+ STL
3	SEAT RING	A182-F11+ STL
4	STEM	A276 410
5	GASKET	304 + GRAPHITE
6	BONNET BOLT	A193 B16/A194-7
7	BONNET	A182-F11
8	PACKING	GRAPHITE
9	GLAND BOLT	A193 B16

NO.	PART NAME	STANDARD
10	GLAND BOLT PIN	A276 304
11	GLAND	A276 420
12	GLAND FLANGE	A105N
13	NUT	A194 7
14	STEM NUT	A276 410
15	WASHER	A276 410
16	NAMEPLATE	ALUMINUM
17	HAND WHEEL NUT	A194 2H
18	HAND WHEEL	A197

SIZE	DIMENSIONS IN INCHES											Weight (lbs)
	L±0.06	d +0.04 -0.02	D1±0.04	D2±0.02	D3±0.06	D±0.08	T +0.08 -0.02	t±0.02	n-b±0.04	H±0.2	W±0.2	
1/2"	8.50	Ø 0.37	Ø 0.63	Ø 1.37	Ø 3.25	Ø 4.72	1.16	0.25	4 @ Ø 0.89	7.64	4.72	15
3/4"	9.01	Ø 0.49	Ø 0.83	Ø 1.69	Ø 3.50	Ø 5.12	1.30	0.25	4 @ Ø 0.89	7.64	4.72	20
1"	10.00	Ø 0.69	Ø 1.04	Ø 2.00	Ø 4.00	Ø 5.90	1.42	0.25	4 @ Ø 1.00	9.13	6.30	26
1-1/2"	12.00	Ø 1.12	Ø 1.61	Ø 2.87	Ø 4.87	Ø 7.09	1.54	0.25	4 @ Ø 1.14	12.13	8.66	48
2"	14.49	Ø 1.44	Ø 2.07	Ø 3.63	Ø 6.50	Ø 8.46	1.79	0.25	8 @ Ø 1.00	14.57	10.24	78

Steamco Fig. 1128

CLASS 150 FLANGED GLOBE VALVE RF F11