

Fig # 600-16-RJ

Applicable Standards:

Steel Gate Valves, API 600/API 6D
 Steel Gate Valves, ISO 10434/ISO 14313
 Steel Valves ASME B16.34
 Face to Face, ASME B16.10
 End Flanges, ASME B16.5
 Inspection and Test, API 598/API 6D

Design

3-1/8" Bore Design
 OS & Y, Outside Screw and Yoke
 BB, Bolted Bonnet
 Flexible Wedge
 Forged T-head Stem
 Rising Stem and Non-rising Handwheel

NO	PART NAME	MATERIAL
01	Body	ASTM A216-WCB
02	Seat	ASTM A105+STL
03	Wedge Disc	ASTM A216-WCB+STL
04	Stem	17-4 PH
05	Bonnet Bolt	ASTM A193 Gr.B7
06	Bonnet Bolt Nut	ASTM A194 Gr.2H
07	Gasket	Graphite+304
08	Bonnet	ASTM A216-WCB
09	Back seat	Integral Metal Deposit STL
10	Packing	Chesterton 1724
11	Stem Nut	Copper Alloy
12	Handwheel	ASTM A47-32510

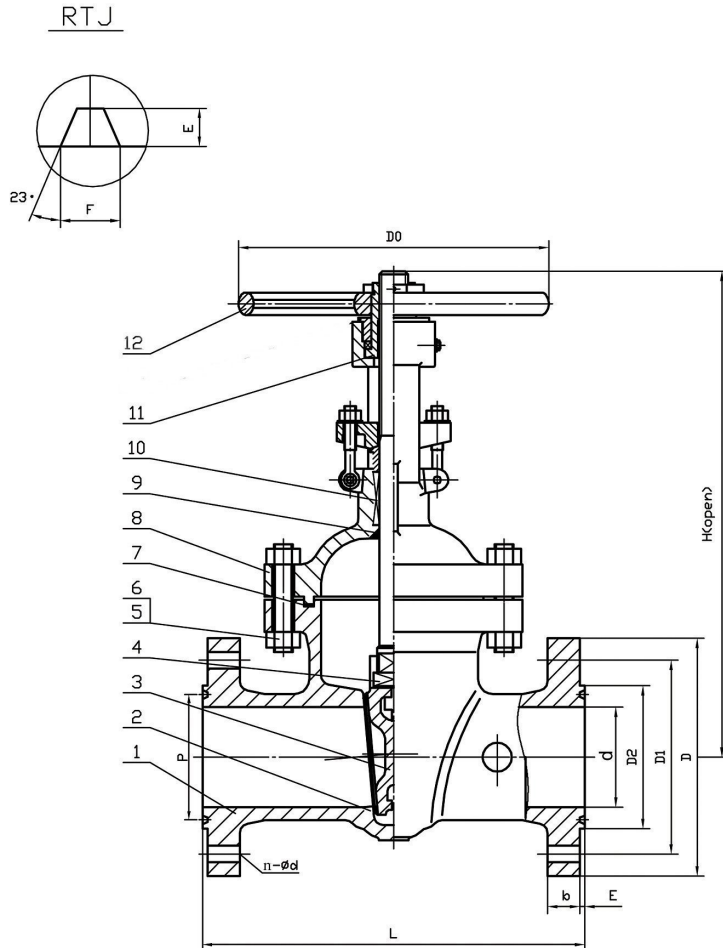

Dimensions

NPS	Typical Dimensions (in)				Class 600 LB Flange Dimensions (in)								WT	
	d	L	H	DO	D	D1	D2	b	P	E	F	n	φd	Lbs
3	3.125	14.13	18.11	11.81	8.28	6.61	5.74	1.25	4.87	0.31	0.46	8	0.86	132