



TITAN FLOW CONTROL, INC.

CHECK VALVE ♦ WAFER TYPE ♦ DUAL DISC

ANSI CLASS 150 ♦ DUCTILE IRON BODY ♦ NSF COATING

MODEL: CV 41A-DI

Body: Ductile Iron

Seats: Buna

Discs: Stainless Steel

**NEWLY
DESIGNED...**
Meets API 594.

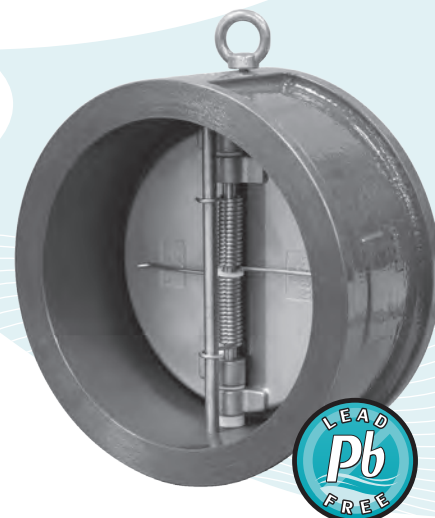
NSF APPROVED
COATINGLEAD FREE BODY
AND COMPONENTSMEETS API 594
ANSI CLASS 125

FEATURES

SIZES: 2" ~ 24"

LARGER SIZES AVAILABLE
UPON REQUEST

◆ COMPLIES WITH API 594 DIMENSIONS

THE CV41A-DI MEETS API 594 ANSI CLASS 125 FACE-TO-FACE DIMENSIONS. THIS ALLOWS THE CV41A-DI TO BE A NATURAL REPLACEMENT FOR OUTDATED CAST IRON VALVES WHILE ACHIEVING THE SUPERIOR MATERIAL BENEFITS OF DUCTILE IRON.

◆ NSF APPROVED COATING

THE BODY OF THIS VALVE IS COATED WITH TNEC SERIES 141 EPOXOLINE. THIS COATING OFFERS HIGH-BUILD EDGE PROTECTION AND EXCELLENT CORROSION RESISTANCE. THIS COATING IS CERTIFIED BY NSF INTERNATIONAL IN ACCORDANCE WITH NSF/ANSI STANDARD 61.

◆ DUCTILE IRON BODY

DUCTILE IRON BODY MAINTAINS THE ANTI-CORROSIVE PROPERTIES OF CAST IRON WHILE ACHIEVING A YIELD STRENGTH COMPARABLE TO CARBON STEEL. DUCTILE IRON ALSO OFFERS HIGHER PRESSURE/TEMPERATURE RATINGS THAN CAST IRON.

◆ COST EFFICIENT DESIGN

LOW WEIGHT AND SHORT LAYING LENGTH PRODUCE SAVINGS IN INITIAL COST, SPACE REQUIREMENTS, AND INSTALLATION WHEN COMPARED TO FULL-BODY, SWING-TYPE CHECK VALVES.

◆ MINIMAL HEAD LOSS

CONTOUR OF BODY PROVIDES A SHORT AND STRAIGHT FLOW PATH THAT GENERATES VERY LITTLE TURBULENCE. ADDITIONALLY, THE SPRING-LOADED DISCS ARE DESIGNED WITH VERY LOW CRACKING PRESSURE WHICH REDUCES THE AMOUNT OF ENERGY REQUIRED TO OPEN THE VALVE.

◆ QUICK CLOSURE TO REDUCE WATER HAMMER

SHUT-OFF IS ACHIEVED VIA THE FULLY AUTOMATIC, SPRING-ASSISTED DISCS THAT CLOSE NEAR ZERO FLOW VELOCITY. THE LIGHTWEIGHT, SPLIT DISC DESIGN CREATES A POSITIVE SHUTOFF PRIOR TO FLOW REVERSAL AND HELPS TO KEEP SLAMMING AND SURGES TO A MINIMUM.

TECHNICAL

PRESSURE/TEMPERATURE RATING
DI - ASTM A536 - CLASS 150 - 2" ~ 24"

WOG (Non-shock): 250 PSI @ 100 °F

SEAT MATERIAL
TEMPERATURE RANGE

BUNA-N: -20 ~ 250 °F

SPRING MATERIAL
MAXIMUM TEMPERATURE

Series 300 Stainless Steel: 450 °F

APPLICATIONS

BUNA-N PROPERTIES: MOST WIDELY USED ELASTOMER. GOOD FOR MOST PETROLEUM OILS AND FLUIDS, SILICONE GREASES AND OILS, AND COLD WATER. EXCELLENT COMPRESSION SET, TEAR, AND ABRASION RESISTANCE. POOR WEATHER RESISTANCE AND MODERATE HEAT RESISTANCE. NOT RECOMMENDED FOR SEVERE OZONE-RESISTANT APPLICATIONS.

The above data represents common market and service applications. No representation or guarantee, expressed or implied, is given due to the numerous variations of concentrations, temperatures and flow conditions that may occur during actual service.

TITAN FLOW CONTROL, INC.

YOUR PIPELINE TO THE FUTURE!

Tel: 910-735-0000 ♦ Fax: 910-738-3848 ♦ titan@titanfci.com ♦ www.titanfci.com
290 Corporate Drive ♦ PO Box 7408 ♦ Lumberton, NC 28358



TITAN FLOW CONTROL, Inc.
 290 Corporate Drive
 Lumberton, NC 28358
 Tel: 910.735.0000
 E-mail: titan@titanfci.com
 Web: www.titanfci.com
 Fax: 910.738.3848

CHECK VALVE • WAFER TYPE • DUAL DISC

MODEL: CV 41A-DI (Ductile Iron Body)

Buna-N Seat • Stainless Steel

ANSI
 Class
 150

BILL OF MATERIALS ⁽¹⁾

No.	PART	CV 41-DI ⁽³⁾
1	Body	Ductile Iron ASTM A536
2	Seat	Buna-N ⁽⁵⁾
3	Disc	Series 300 Stainless Steel
4	Spring ⁽²⁾	Series 300 Stainless Steel
5	Shaft/Stop Pin	Series 300 Stainless Steel
6	Set Screw	Commercial Steel
7	Eye Bolt ⁽⁴⁾	Commercial Steel
8	Seal Plug	Buna-N

1. Bill of Materials represents standard materials. Equivalent or better materials may be substituted at the manufacturer's discretion.
2. Denotes recommended spare parts.
3. Ductile Iron bodies are NSF coated.
4. Eye Bolt is available on larger sizes only.
5. Contact factory for other available materials.

Ductile Iron Application Notes:

Ductile Iron maintains the anti-corrosive properties of Cast Iron while achieving a yield strength comparable to Carbon Steel. Ductile Iron also offers higher pressure/temperature ratings than Cast Iron. Ductile Iron ANSI Class 150 has the same bolting pattern as Cast Iron ANSI Class 125.

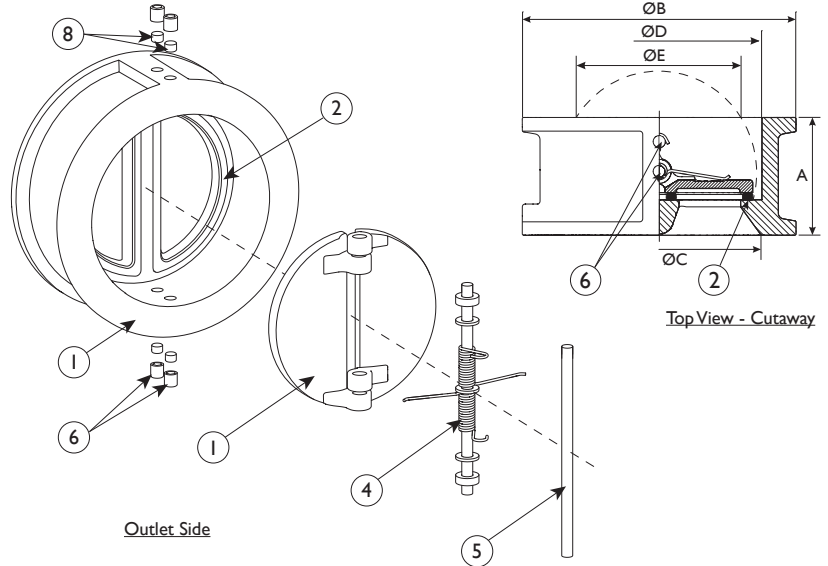

DIMENSIONS AND PERFORMANCE DATA ⁽¹⁾

SIZE	in	2	2 1/2	3	4	5	6	8	10	12	14	16	18	20	24
	mm	50	65	80	100	125	150	200	250	300	350	400	450	500	600
A DIMENSION FACE TO FACE ⁽²⁾	in	2.12	2.38	2.62	2.62	3.25	3.75	5.00	5.50	7.12	7.25	7.50	8.00	8.38	8.75
	mm	54	60	67	67	83	95	127	140	181	184	191	203	213	222
$\varnothing B$ DIMENSION OUTLET OUTSIDE DIAMETER	in	4.02	4.76	5.24	6.73	7.60	8.62	10.87	13.23	15.98	17.64	20.12	21.50	23.74	28.11
	mm	102	121	133	171	193	219	276	336	406	448	511	546	603	714
$\varnothing C$ DIMENSION INLET INSIDE DIAMETER	in	2.52	2.95	3.54	4.32	5.67	6.70	8.82	10.43	12.21	14.17	16.13	17.32	20.10	23.66
	mm	64	75	90	110	144	170	224	265	310	360	410	440	511	601
$\varnothing D$ DIMENSION OUTLET INSIDE DIAMETER	in	2.56	3.15	3.70	4.61	5.71	6.69	8.82	10.43	12.20	14.17	16.14	17.72	19.88	24.57
	mm	65	80	94	117	145	170	224	265	310	360	410	450	505	624
$\varnothing E$ DIMENSION MINIMUM BORE DIAMETER	in	1.50	1.98	2.78	3.88	4.53	5.49	7.40	9.14	10.65	12.97	14.63	16.26	18.17	22.62
	mm	38	50	71	99	115	140	188	232	271	330	372	413	462	575
ASSEMBLED WEIGHT	lb	4.0	5.0	7.0	14.0	18.0	26.5	43.0	70.0	108.0	175.0	200.0	258.0	345.0	460.0
	kg	1.8	2.3	3.2	6.3	8.2	12.0	19.5	31.7	48.9	79.4	90.7	117.0	156.5	208.7
Flow Coefficient	C_v	62	110	175	350	550	850	1500	2400	3700	5400	8250	10400	14200	23000
Cracking Pressure ⁽³⁾	psi	≤ .25	≤ .25	≤ .25	≤ .25	≤ .25	≤ .25	≤ .25	≤ .25	≤ .25	≤ .25	≤ .25	≤ .25	≤ .25	≤ .25

1. Dimensions and weights are for reference only. When required, request certified drawings.
2. Face to face values have a tolerance of ± 0.06 in (± 2.0 mm) for sizes 10" and lower and a tolerance of ± 0.12 in (± 3.0 mm) for sizes 12" and larger.

3. Cracking pressure is for horizontal installations only. For vertical installations, please consult factory.

PRESSURE - TEMPERATURE RATINGS ⁽¹⁾

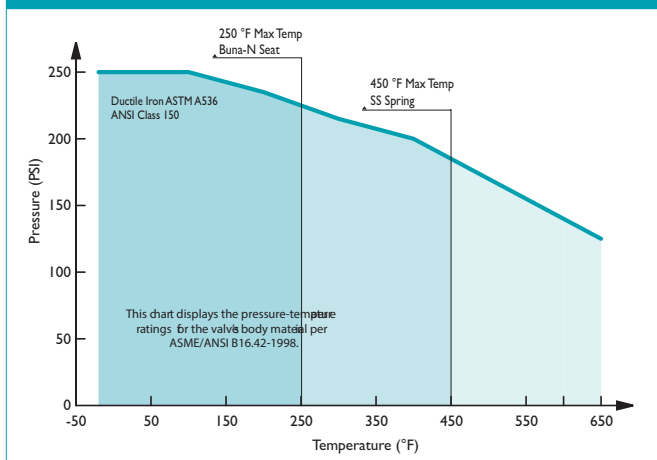

1. The above chart displays the pressure-temperature ratings for the valve's body material per ASME B16.42-1998. Max temperature limits have been added for seat and spring materials.

REFERENCED STANDARDS & CODES

CODE	DESCRIPTION
ANSI/API 594	Valve Design and Manufacture
ASME/ANSI 16.5	Pipe Flanges and Flanged Fittings
ASME/ANSI B16.34	Valves - Flanged, Threaded, and Welding End
ASME/ANSI B16.42	Ductile Iron Pipe Flanges and Flanged Fittings
API 598	Valve Inspection and Pressure Test

PRESSURE / TEMPERATURE RATING - ASTM A536

Body Material	Class 150 (2" ~ 24")
WOG (Non-shock):	250 PSI @ 100 °F

SEAT AND SPRING TEMPERATURE RATING

Seat Material	Range	Spring Material	Max
BUNA-N:	-20 ~ 250 °F	Series 300 Stainless Steel:	450 °F

Titan FCI makes every effort to ensure the information presented on our literature accurately reflects exact product specifications. However, as product changes occur, there may be short-term differences between actual product specifications and the information contained within our literature. Titan FCI reserves the right to make design and specification changes to improve our products without prior notification. When required, request certified drawings.