

# Steamco Valves

**APPLICABLE STANDARDS**  
 BASIC DESIGN: API 602 & ASME B16.34  
 TEST AND INSPECTION: API 598

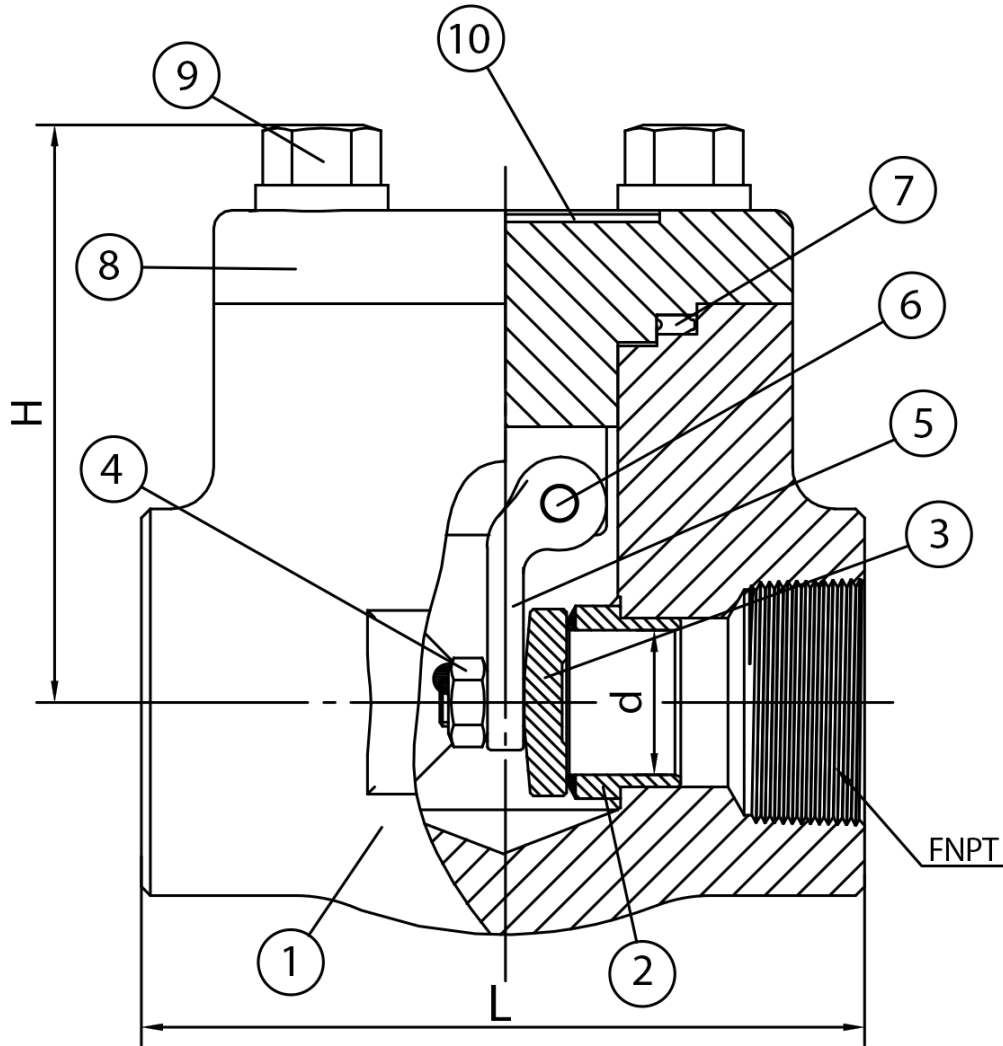

NO.	PART NAME	STANDARD
1	BODY	A105N
2	SEAT RING	A276 410 + STL
3	DISC	A276 420
4	DISC NUT	A194 8M
5	ROCKER	A351 CF8M

NO.	PART NAME	STANDARD
6	PIN	A276 316
7	GASKET	304 + GRAPHITE
8	BONNET	A105N
9	BONNET BOLT	A193 B7
10	NAMEPLATE	ALUMINUM

SIZE	DIMENSIONS IN INCHES				Weight (lbs)
	L±0.06	d±0.02	FNPT	H±0.2	
1/2"	3.11	Ø 0.51	1/2"	2.28	3.0
3/4"	3.62	Ø 0.51	3/4"	2.28	3.5
1"	4.37	Ø 0.71	1"	2.95	6.0
1-1/4"	4.72	Ø 0.94	1-1/4"	3.27	8.5
1-1/2"	4.72	Ø 1.14	1-1/2"	3.70	10.0
2"	5.51	Ø 1.44	2"	4.20	39.0

**Steamco Fig. SC800FS8T**

**CLASS 800 THD SWING CHECK**