

Steamco Valves

APPLICABLE STANDARDS

BASIC DESIGN: BS 1868

FLANGE DIMENSIONS: ASME B16.5

FACE TO FACE DIMENSIONS: ASME

B16.10 WORKING PRESSURE: 600 PSI

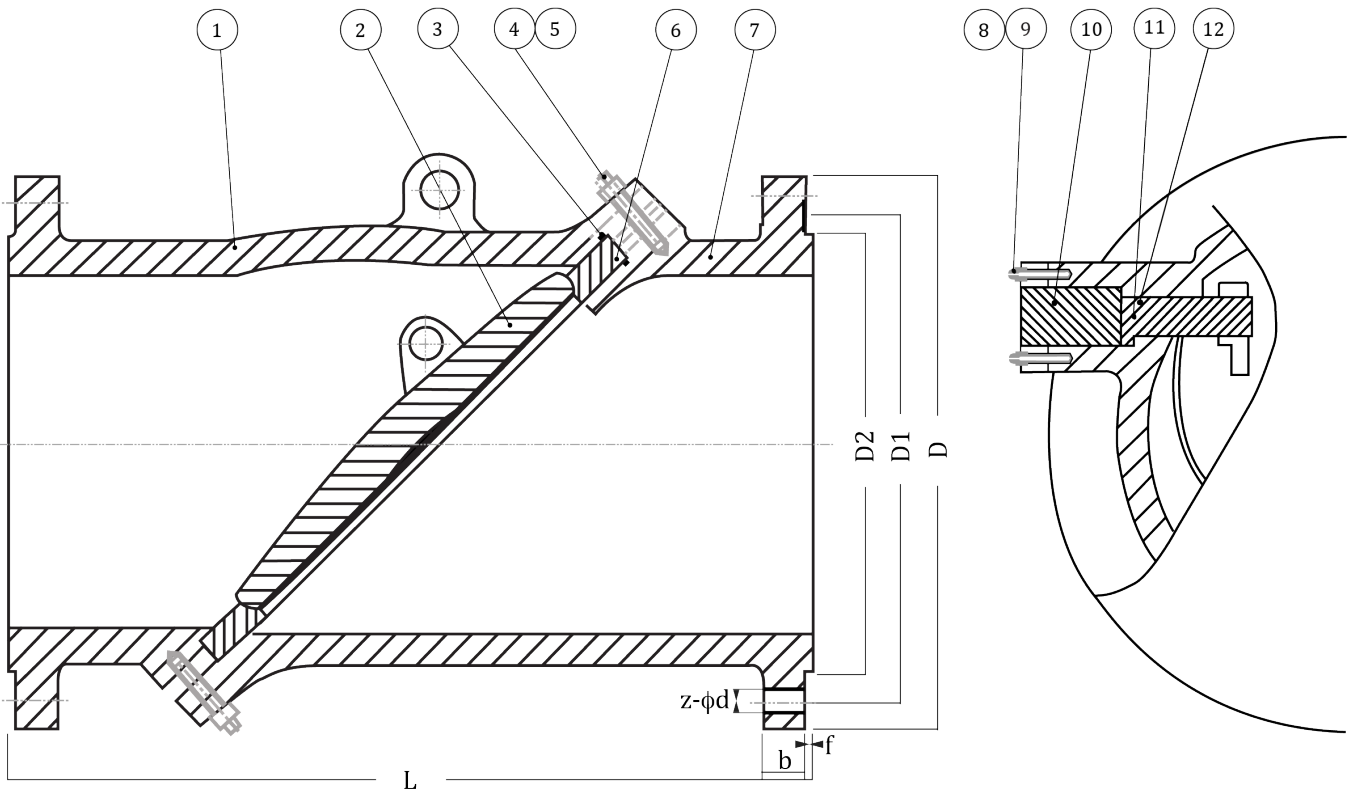

SIZE	A	B	C	D	E	n	f
3	14.00	8.30	6.60	5.00	1.25	8x0.875	0.25
4	17.00	10.75	8.50	6.19	1.50	8x1.00	0.25
6	22.00	14.00	11.50	8.50	1.88	12x1.125	0.25
8	26.00	16.50	13.75	10.62	2.19	12x1.13	0.25

NO.	PART NAME	STANDARD
1	OUTLET BODY	ASTM A216 WCB
2	DISC	ASTM A217 CA15*
3	GASKET	SS304 + GRAPHITE
4	NUT	ASTM A194 2H
5	BOLT	ASTM A193 B7
6	SEAT	ASTM A105 + STL6
7	INLET BODY	ASTM A216 WCB
8	NUT	ASTM A194 2H
9	BOLT	ASTM A193 B7
10	END CAP	ASTM A216 WCB
11	PIN	ASTM A182 F6
12	GASKET	SS304

*WCB FOR 8" AND LARGER

Steamco Fig. TD600CSF8

CLASS 600 FLANGED TILTING CHECK VALVE