

# Steamco Valves

## APPLICABLE STANDARDS

BASIC DESIGN: MSS SP-71  
 FACE TO FACE DIMS: ANSI B16.10  
 FLANGE DRILLING: ANSI B16.1  
 WORKING PRESSURE: 250 PSI

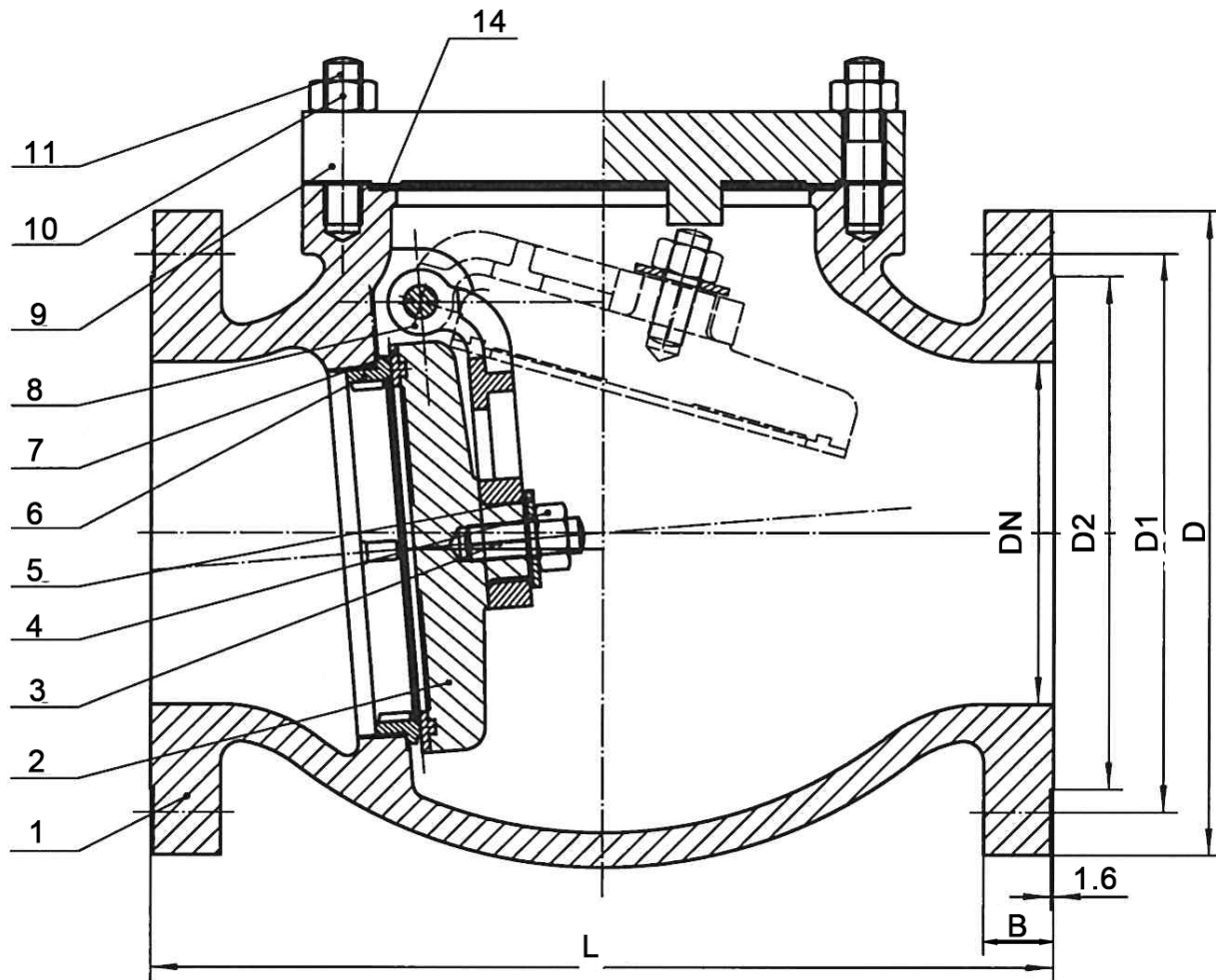

NO.	PART NAME	STANDARD
1	BODY	ASTM A126 B
2	DISC - 2" - 3"	ASTM B584
	DISC - 4" - 8"	ASTM A126 B
3	DISC BOLT	ASTM A108
4	DISC NUT	ASTM A563 GR. A
5	WASHER	Q235 A
6	SEAT	ASTM B584
7	DISC RING	ASTM B584
8	ROCKER	ASTM A536
9	BONNET	ASTM A126 B
10	BONNET NUT	ASTM A563 GR. A
11	BONNET BOLT	ASTM A108
12	PLUG	ASTM B16
13	ROCKER PIN - 2" - 3"	ASTM A276 TY. 410
13	ROCKER PIN - 4" - 8"	ASTM B21
14	GASKET	08 + GRAPHITE

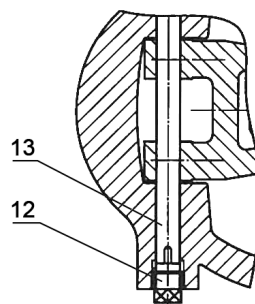

TEMPERATURE RATINGS	
Temp F.	PSI Non-Shock
-20 to 150	500
200	460
225	440
250	415
275	395
300	375
325	355
350	335
375	315
400	290
425	270
450	250

SIZE	L	D	D1	D2	B	BOLT HOLES
2	10.50	6-1/2	5	3-5/8	7/8	8 x 3/4
3	12.50	8-1/4	6-5/8	5	1-1/8	8 x 7/8
4	14.00	10	7-7/8	6-3/16	1-1/4	8 x 7/8
6	17.00	12-1/2	10-5/8	8-1/2	1-7/16	12 x 7/8
8	21.00	15	13	10-5/8	1-5/8	12 x 1

**Steamco Fig. 258A**

**CLASS 250 IRON BODY SWING CHECK**