

Fig # 150-16

Applicable Standards:

Steel Gate Valves, API 600/API 6D
 Steel Gate Valves, ISO 10434/ISO 14313
 Steel Valves, ASME B16.34
 Face to Face, ASME B16.10
 End Flange ASME B16.5
 Inspection and Test, API 598/API 6D

Design:

OS & Y, Outside Screw and Yoke
 BB, Bolted Bonnet
 Flexible Wedge
 Forged T-head Stem
 Rising Stem and Non-rising Handwheel

NO	PART NAME	MATERIAL
01	Body	ASTM A216-WCB
02	Seat	ASTM A105+STL
03	Solid Wedge Disc	ASTM A216-WCB+STL
04	Stem	17-4 PH
05	Bonnet Bolt	ASTM A193 Gr.B7
06	Bonnet Bolt Nut	ASTM A194 Gr.2H
07	Gasket	Graphite+304
08	Bonnet	ASTM A216-WCB
09	Packing	Customer Specified
10	Back Seat	Integral Metal Deposited STL
11	Stem Nut	Copper Alloy
12	Handwheel	ASTM A47-32510

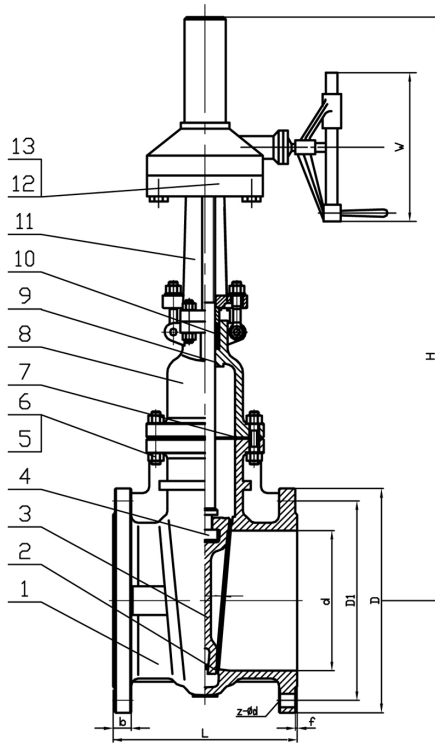

NPS	Typical Dimensions (in)				Class 150LB Flange Dimensions (in)							WT Lbs
	d	L	H	DO	D	D1	D2	b	f	n	φd	
30	29.00	24.00	95.00	23.5	38.75	36.00	33.75	2.94	0.06	28	1.38	5600
36	34.50	28.00	107.5	23.5	46.00	42.75	40.25	3.56	0.06	32	1.62	7700