

Steamco Valves

APPLICABLE STANDARDS

BASIC DESIGN: MSS SP-70, ASME B16.34
 FLANGE DIMENSIONS: ASME B16.1
 FACE TO FACE DIMENSIONS: ASME B16.10

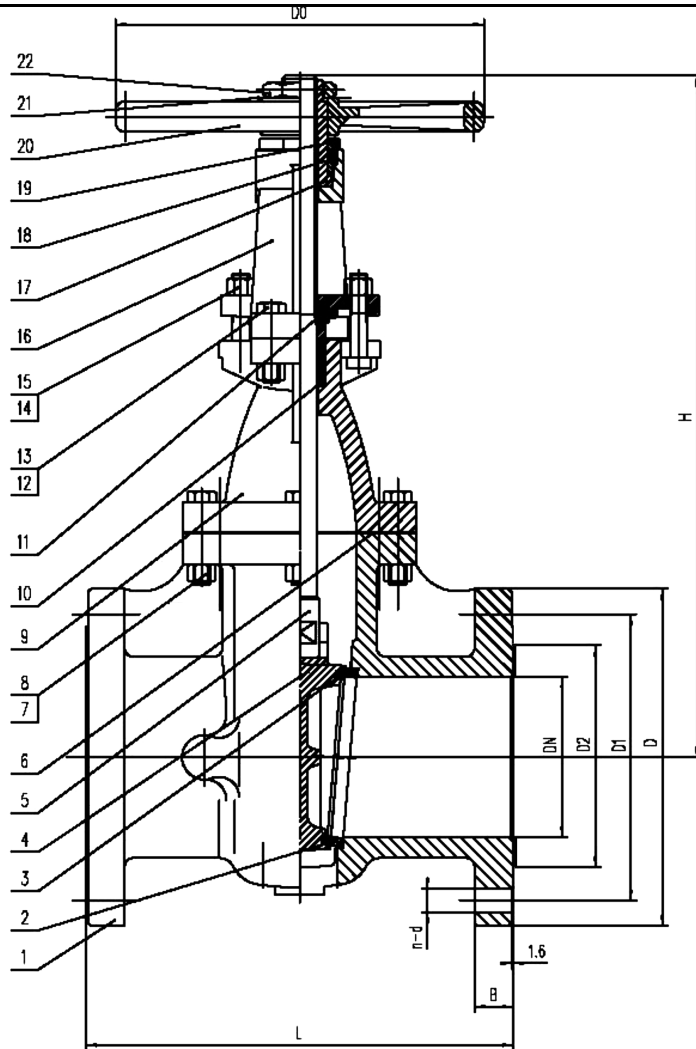

SIZE	L	D	D1	D2	B	n-d	D0	H	WEIGHT
2"	8-1/2	6-1/2	5"	4-1/4	13/16	8 x 3/4	6-5/16	12-4/5	55
2 1/2"	9-1/2	7-1/2	5-7/8	5"	1"	8 x 7/8	8"	13	74
3"	11-1/8	8-1/4	6-5/8	5-11/16	1-1/6	8 x 7/8	10"	16	114
4"	12"	10"	7-7/8	7"	1-1/4	8 x 7/8	12"	19-2/5	174
5"	15"	11"	9-1/4	8-1/4	1-3/8	8 x 7/8	12"	22-4/5	285
6"	15 7/8"	12-1/2	10-5/8	9-1/2	1-7/16	12 x 7/8	14"	25-2/5	352
8"	16-1/2	15"	13"	12"	1-5/8	12 x 1"	16"	31-3/10	610
10"	18"	17-1/2	15-1/4	14"	1-7/8	16 x 1-1/8	18"	36-4/5	897
12"	19-3/4	20-1/2	17-3/4	16-1/2	2"	16 x 1-1/4	18"	41-7/10	1272

NO.	PART NAME	MATERIAL	STANDARD	NO.	PART NAME	MATERIAL	STANDARD
1	BODY	CAST IRON	ASTM A126B	12	BOLTS	STEEL	ASTM A307 B
2	SEAT RING	CAST BRONZE	ASTM B62	13	NUTS	STEEL	ASTM A307 B
3	WEDGE FACE RING	CAST BRONZE	ASTM B62	14	BOLTS	STEEL	ASTM A307 B
4	WEDGE	CAST IRON	ASTM A126B	15	NUTS	STEEL	ASTM A307 B
5	STEM	BRASS	ASTM B16	16	YOKE	CAST IRON	ASTM A126B
6	GASKET	GRAPHITE	NON ASBESTOS	17	NUT	CAST BRASS	MN BRASS
7	BOLTS	STEEL	ASTM A307 B	18	SCREW	STEEL	ASTM A307 B
8	NUTS	STEEL	ASTM A307 B	19	YOKE BUSHING NUT	CAST IRON	ASTM A126B
9	BONNET	CAST IRON	ASTM A126B	20	HANDWHEEL	CAST IRON	ASTM A126B
10	PACKING	GRAPHITE	NON ASBESTOS	21	NAME PLATE	ALUMINUM	COMMERCIAL
11	GLAND FOLLOWER	DUCTILE IRON	ASTM A 536	22	NUT	STEEL	ASTM A307 B

Steamco Fig. 250A

CLASS 250 FLANGED RISING STEM GATE VALVE