



TITAN FLOW CONTROL, INC.

FULL BODY SWING CHECK VALVE ♦ FLANGED ENDS ♦ SINGLE DISC

ANSI CLASS 125 ♦ CAST IRON BODY

MODELS: CV 31F-CI

Body: Cast Iron
Body Seat: Bronze
Disc: Cast Iron
Disc Seat: Buna-N

CV 31WF-CI

Body: Cast Iron
Body Seat: Bronze
Disc: Cast Iron
Disc Seat: Buna-N
Weight & Lever: Cast Iron



SIZES: 2" ~ 12"

FEATURES

◆ PROVEN DESIGN

THE FULL BODY SWING CHECK IS ONE OF THE MOST WELL-KNOWN TYPES OF CHECK VALVES. A PROVEN DESIGN, IT IS IDEAL FOR PREVENTING FLOW REVERSAL WHICH AIDS IN PROTECTING PUMPS, COMPRESSORS, AND DOWNSTREAM TANKS AND VESSELS. THE TITAN CV31F CAN ALSO BE USED TO ISOLATE HIGH PRESSURE SYSTEMS FROM LOW PRESSURE SYSTEMS AND TO PREVENT CONTAMINATION BETWEEN SYSTEMS.

◆ LESSEN WATER HAMMER

THE TITAN CV31F CAN BE EQUIPPED WITH ADJUSTABLE WEIGHTS AND LEVERS TO PREVENT THE DISC FROM OPENING UNTIL A DESIRED PRESSURE IS REACHED. THE WEIGHTS AND LEVERS PROVIDE QUICKER CLOSING AND AID IN THE REDUCTION OF SLAMMING BY KEEPING THE DISC WITHIN THE FLUID FLOW. THE WEIGHTS AND LEVERS PROVIDE THE ADDITIONAL BENEFIT OF VISUALLY DISPLAYING THE POSITION OF THE DISC.

◆ HEAD LOSS

THE TITAN CV31F IS FULLY PORTED WITH A STRAIGHT-FLOW-PATH THAT IS VIRTUALLY UNOBSTRUCTED AND AIDS IN REDUCING HEAD LOSS.

◆ RESILIENT SOFT SEAT

THE SOFT SEAT (BUNA-N) DISC SEAT COUPLED WITH PRECISION MACHINED SEALING SURFACES HELPS TO ENSURE A DROP-TIGHT SEAL THAT MEETS AWWA C508. THE BUNA-N SEAT PROVIDES EXCELLENT COMPRESSION SET, TEAR, AND ABRASION RESISTANCE. IT IS APPLICABLE FOR MOST WATER, WASTEWATER, AND PETROLEUM APPLICATIONS.

◆ DURABLE CONSTRUCTION

THE CV31F IS A ONE-PIECE, CAST IRON BODY DESIGN WITH A BOLTED COVER. SPECIAL COATINGS CONFORMING TO AWWA C508 ARE AVAILABLE.

TECHNICAL

PRESSURE/TEMPERATURE RATING

WOG (Non-shock): 200 PSI @ 125 °F

HYDROSTATIC SHELL TEST

2 × WOG for 60 seconds = 400 PSI

SEAT TEST

1 × WOG for 15 seconds applied on downstream side of disc.

1. The above listed temperatures are theoretical and may vary during actual operating conditions.
2. Duration of test is defined by AWWA C508 spec.



The CV 31WF-CI comes equipped with a weight and lever.

APPLICATIONS

MARKETS: WATER & WASTEWATER, PULP & PAPER, CHEMICAL & PETROCHEMICAL, PETROLEUM, OIL & GAS.

The above data represents common market and service applications. No representation or guarantee, expressed or implied, is given due to the numerous variations of concentrations, temperatures and flow conditions that may occur during actual service.

TITAN FLOW CONTROL, INC.

YOUR PIPELINE TO THE FUTURE!

Tel: 910-735-0000 ♦ Fax: 910-738-3848 ♦ titan@titanfci.com ♦ www.titanfci.com
290 Corporate Drive ♦ PO Box 7408 ♦ Lumberton, NC 28358



TITAN FLOW CONTROL, Inc.
 290 Corporate Drive
 Lumberton, NC 28358
 Tel: 910.735.0000
 Fax: 910.738.3848

E-mail: titan@titanfci.com
 Web: www.titanfci.com

FULL BODY SWING CHECK VALVE • FLANGED ENDS • SINGLE DISC

**MODEL: CV 31F-CI (Cast Iron Body)
 CV 31WF-CI (Cast Iron Body)**

Bronze Seat • Cast Iron/Buna-N Disc

**ANSI
 Class
 125**

BILL OF MATERIALS (1)

No.	PART	CV 31F-CI
1	Body	Cast Iron ASTM A126 Gr.B
2	Body Seat	Bronze ASTM B62 C83600
3	Disc	Cast Iron ASTM A126 Gr.B
4	Side Plug	Brass ASTM B16 C36000
5	Cover	Cast Iron ASTM A126 Gr.B
6	Hanger Pin	Stainless Steel AISI 420
7	Hanger	Ductile Iron ASTM A536 65-45-12
8	Gasket	Non-asbestos
9	Disc Seat	Buna-N

1. Bill of Materials represents standard materials. Equivalent or better materials may be substituted at the manufacturer's discretion. All materials conform to ASTM specifications.

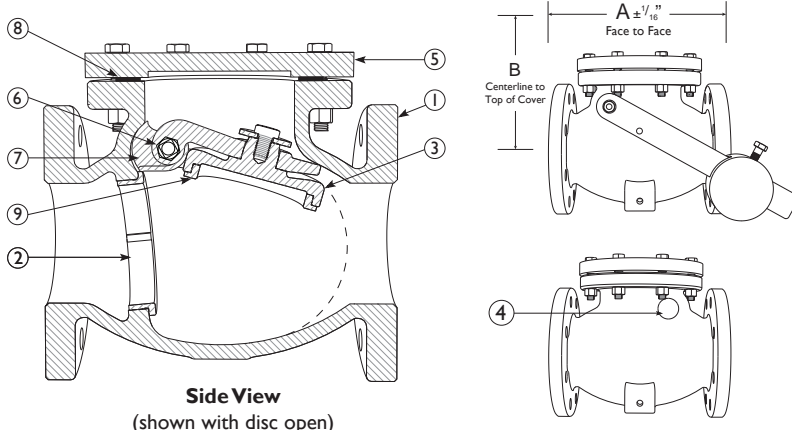

Side View
(shown with disc open)

DIMENSIONS AND PERFORMANCE DATA (1)

SIZE	in	2	2 1/2	3	4	5	6	8	10	12
	mm	50	65	80	100	125	150	200	250	300
A DIMENSION FACE TO FACE (2)(3)	in	8.00	8.50	9.50	11.50	13.00	14.00	19.50	24.50	27.52
	mm	203	216	241	292	330	356	495	622	699
ØB DIMENSION CENTER LINE TO TOP	in	5.00	5.40	5.79	6.54	7.50	8.55	10.45	11.81	13.47
	mm	127	137	147	166	191	217	265	300	342
ASSEMBLED WEIGHT WITHOUT WEIGHT AND LEVER	lb	25.35	36.38	46.30	55.12	92.60	110.0	230.0	370.38	537.93
	kg	11.50	16.50	21.00	25.00	42.00	50.00	104.00	168.00	244.00
ASSEMBLED WEIGHT WITH WEIGHT AND LEVER	lb	38.50	49.60	58.20	92.60	134.92	170.64	287.0	453.0	660.30
	kg	17.50	22.50	26.40	42.00	61.20	77.40	130.20	205.50	299.50
Flow Coefficient WITHOUT WEIGHT AND LEVER	C _v	48	76	109	198	310	446	801	1260	1821

1. Dimensions, weights, and flow coefficients are for reference only. When required, request certified drawings.
2. Face to face values have a tolerance of ±0.06 in (±2.0 mm) for sizes 10" and lower and a tolerance of ±0.12 in (±3.0 mm) for sizes 12" and larger.
3. Face to face values meet AWWA C508 spec for "full waterway" valves.

PRESSURE DROP CHART (1)

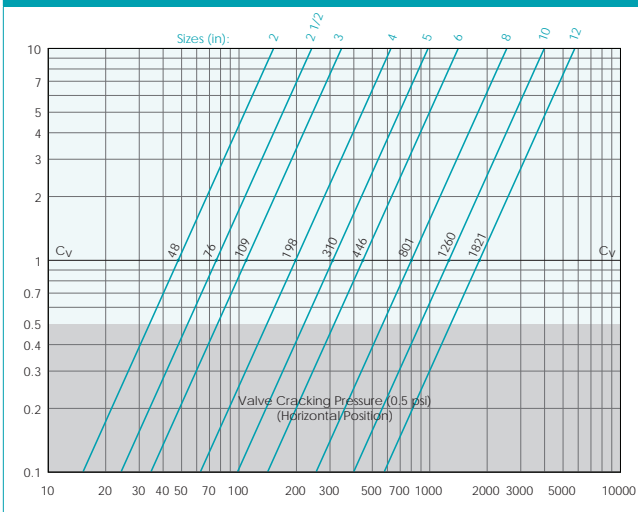

1. This chart displays Cv values for the CV 31-F. Consult factory for information on the CV 31WF-CI.

REFERENCED STANDARDS & CODES

CODE	DESCRIPTION
ANSI B16.1	Cast Iron Pipe Flanges and Flanged Fittings Class 125.
ANSI B16.10	Face to Face & End to End Dimensions of Valves.
MSS SP-71	Gray Iron Swing Check Valves, Flanged and Threaded End.
AWWA C508	Swing Check Valves for Waterworks Service.

PRESSURE - TEMPERATURE RATING

ANSI CLASS 125	A126 Gr. B
WOG (Non-shock):	200 PSI @ 125 °F

1. The listed pressure and temperature ratings for the valve's body and seat are theoretical and may vary during actual operating conditions.

Titan FCI makes every effort to ensure the information presented on our literature accurately reflects exact product specifications. However, as product changes occur, there may be short-term differences between actual product specifications and the information contained within our literature. Titan FCI reserves the right to make design and specification changes to improve our products without prior notification. When required, request certified drawings.