

# Steamco Valves

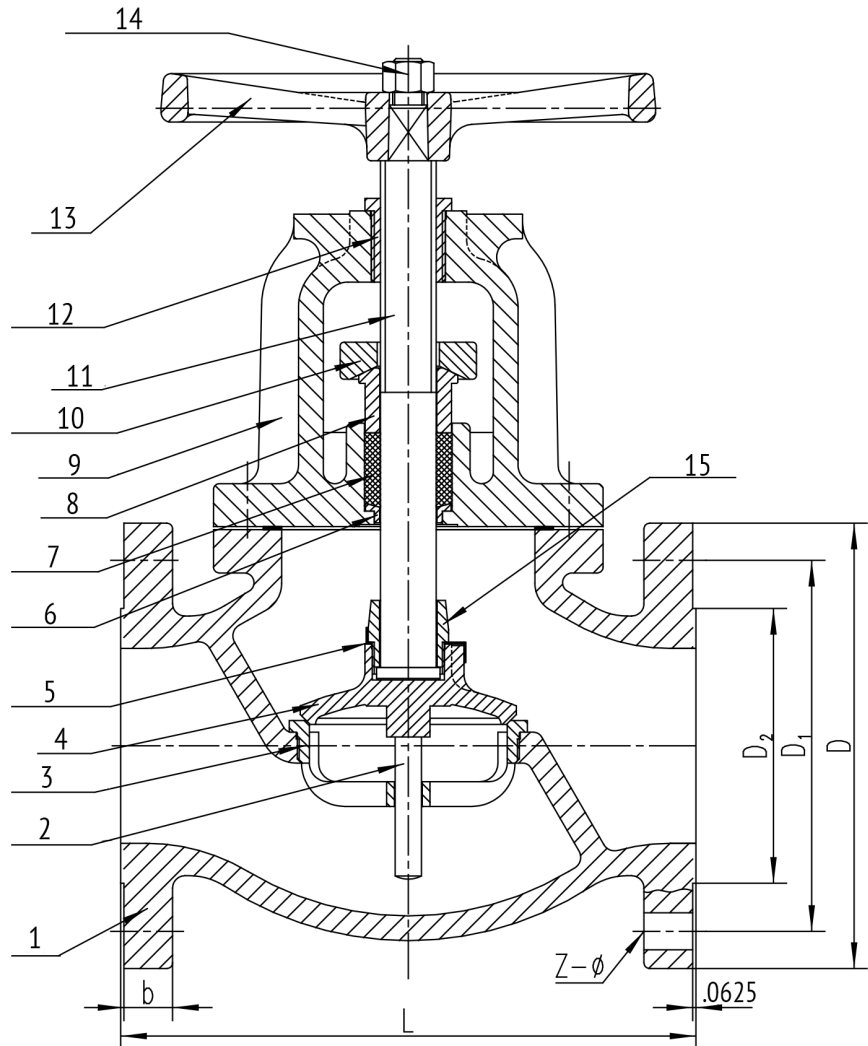

SIZE	L	D	D1	D2	b	Z-OD	WEIGHT
2	10.50	6.50	5.00	3.62	0.88	8 x 0.75	42
2-1/2	11.50	7.50	5.88	4.12	0.94	8 x 0.88	78
3	12.50	8.25	6.62	5.00	1.06	8 x 0.88	96
4	14.00	10.00	7.88	6.19	1.19	8 x 0.88	154
6	17.50	12.50	10.62	8.50	1.38	12 x 0.88	320
8	21.00	15.00	13.00	10.62	1.56	12 x 1.00	546

### APPLICABLE STANDARDS

BASIC DESIGN: MSS SP-85, ASME B16.34  
 FLANGE DIMENSIONS: ASME B16.1  
 FACE TO FACE DIMENSIONS: ASME B16.10  
 WORKING PRESSURE: 250 PSI

NO.	PART NAME	MATERIAL	STANDARD	NO.	PART NAME	MATERIAL	STANDARD
1	BODY	CAST IRON	ASTM A126B	8	GLAND	BRONZE	ASTM B62
2	BOTTOM GUIDE	STEEL	ASTM A108	9	BONNET	CAST IRON	ASTM A126B
3	BODY SEAT RING	BRONZE	ASTM B62	10	GLAND FLANGE	STEEL	ASTM A182 WCB
4	DISC 2-3"	BRONZE	ASTM B62	11	STEM	BRONZE	ASTM B16
4	DISC 4-8"	CAST IRON/BRZ FACING	ASTM A126B/B62	12	YOKE BUSHING	BRONZE	ASTM B62
5	LOCK WASHER	STAINLESS STEEL	18-8	13	HANDWHEEL	MALLEABLE IRON	ASTM A338
6	STEM BUSHING	BRONZE	ASTM B62	14	HANDWHEEL NUT	STEEL	ASTM A307B
7	PACKING	GRAPHITE	NON-ASBESTOS	15	DISC STEM RING	BRONZE	ASTM B62

**Steamco Fig. 256A**

**CLASS 250 IRON BODY GLOBE VALVE**