

Steamco Valves

APPLICABLE STANDARDS

BASIC DESIGN: API 602 and ASME B16.34
 SOCKET WELDING: ASME B16.1
 THREADED END: ASME B1.20.1 (NPT)
 TEST AND INSPECTION: API 598
 1975 PSI @100F

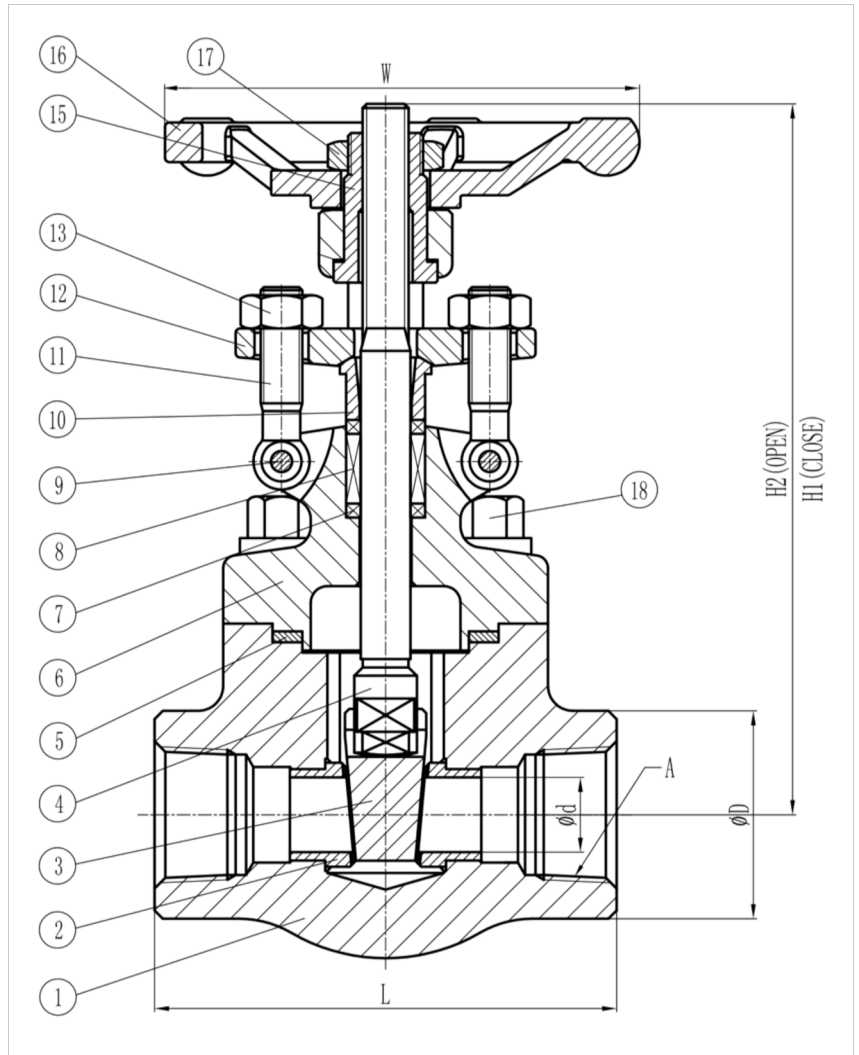

| NO. | PART NAME | MATERIAL | NO. | PART NAME | MATERIAL |
|-----|---------------|--------------------|-----|---------------|----------|
| 1 | BODY | A105N | 10 | GLAND | A276-420 |
| 2 | SEAT | A276-410 + STL | 11 | SWING BOLT | A193-B7 |
| 3 | WEDGE | A276-420 | 12 | GLAND FLANGE | A105 |
| 4 | STEM | A182-F6a | 13 | NUT | A194-2H |
| 5 | BONNET GASKET | SW GRAPHITE + SS | 15 | STEM NUT | A276-410 |
| 6 | BONNET | A105N | 16 | HANDWHEEL | A197 |
| 7 | PACKING | GRAPHITE + SS WIRE | 17 | HANDWHEEL NUT | A194-2H |
| 8 | PACKING | GRAPHITE | 18 | BOLT | A193-B7 |
| 9 | PIN | A276-304 | | | |

| SIZE | L | H1 | H2 | d | D | W | A | WEIGHT |
|--------|------|------|-------|------|------|------|--------|--------|
| 1/2" | 3.11 | 5.39 | 6.02 | 0.51 | 1.34 | 3.94 | 1/2" | 4.2 |
| 3/4" | 3.62 | 5.39 | 6.02 | 0.51 | 1.58 | 3.94 | 3/4" | 4.6 |
| 1" | 4.37 | 6.46 | 7.28 | 0.71 | 1.93 | 4.92 | 1" | 7.6 |
| 1-1/4" | 4.72 | 7.68 | 8.74 | 0.94 | 2.28 | 6.30 | 1-1/4" | 12.0 |
| 1-1/2" | 4.72 | 8.19 | 9.45 | 1.14 | 2.52 | 6.30 | 1-1/2" | 11.8 |
| 2" | 5.51 | 9.37 | 10.98 | 1.45 | 3.07 | 7.09 | 2" | 18.6 |

Steamco Fig. GT800FS8SW

CLASS 800 FORGED STEEL GATE VALVE