

ITEM	NAME	MATERIAL
1	BODY	ASTM A216-WCB
2	SEAT	ASTM A105N+STL
3	FLEXIBLE WEDGE	ASTM A217-CA15
4	STEM	ASTM A182-F6a
5	BONNET	ASTM A216-WCB
6	GASKET	304+GRAPHITE
7	BACKSEAT	ASTM A276-420
8	PACKING SPACER	ASTM A276-410
9	PACKING	INCONEL600+GRAPHITE
10	GLAND	ASTM A276-410
11	GLAND FLANGE	ASTM A216-WCB
12	EYE BOLT	ASTM A193-B7
13	NUT	ASTM A194-2H
14	GREASE FITTING	ASTM A283 GRC
15	GLAND NUT	AISI 1025
16	HANDWHEEL	ASTM A536 60-40-18
17	HANDWHEEL NUT	AISI 1025
18	SCREW	AISI 1025
19	STEM NUT	ASTM A439 D-2
20	PIN	AISI 1035
21	BOLT	ASTM A193-B7
22	NUT	ASTM A194-2H
23	NAMEPLATE	ASTM A240-304
24	RIVET	ASTM A240-304

NOTE:

- 1. FLEXIBLE WEDGE
- 2. API 624 QUALIFIED

ITEM	FIG NO.	SIZE	UNIT	d	A	B	C	D	n	E	F	H	W	S <sub>b</sub>	Weight(lbs/kgs)
01	GT150CSF8	2"	mm	51	178	16.3	150	120.7	4	19	92.1	328	200	8.6	44/20
		2"	in	2.0	7.0	0.64	6.0	4.75	4	3/4	3.62	12.91	7.87	0.34	
02	GT150CSF8	2-1/2"	mm	64	190	17.9	180	139.7	4	19	104.8	359	200	9.7	57/26
		2-1/2"	in	2.5	7.5	0.70	7.0	5.5	4	3/4	4.12	14.13	7.87	0.38	
03	GT150CSF8	3"	mm	76	203	19.5	190	152.4	4	19	127	399	250	10.4	75/34
		3"	in	3.0	8.0	0.77	7.5	6.0	4	3/4	5.0	15.71	9.84	0.41	
04	GT150CSF8	4"	mm	102	229	24.3	230	190.5	8	19	157.2	472	250	11.2	110/50
		4"	in	4.0	9.0	0.96	9.0	7.5	8	3/4	6.19	18.58	9.84	0.44	



**J.J. VALVE**  
Toll Free 800.582.5837 Local 310.605.0090

Here at J.J. Valve, we utilize a wide variety of products to meet your needs when it comes to industrial valves.

TITLE:		CAST STEEL GATE VALVE	
		CLASS 150- API TRIM 8 - RF - HANDWHEEL OPERATED	
MATERIAL:	ASTM A216 WCB	UNITS:	Inch, mm
CLASS:	150	DATE:	4/15/19
SCALE:	N.T.S.	FIG. No.:	
SIZE:	2"~ 4"	DRAWN BY:	F.J.
			<b>GT150CSF8</b>
CHK'D & APR'D BY:	E.C.	REV:	1
DWG No.:			

NO.	DATE	DESCRIPTION	PRP'D	REV'D	APP'D	DESIGNED	MARKING SYSTEM	MSS-SP-25	INSPECTION & TEST: API 598
△	4/15/19	RELEASED	F.J.	E.C.	E.C.		DIM.OF FLANGE	ANSI B16.5	SHELL HYDRO 450PSI
							FACE TO FACE	ANSI B16.10	SEAT AIR 80PSI
							WALL THICKNESS	API 600	BACK SEAT HYDRO 315PSI
									API 600, ANSI B16.34

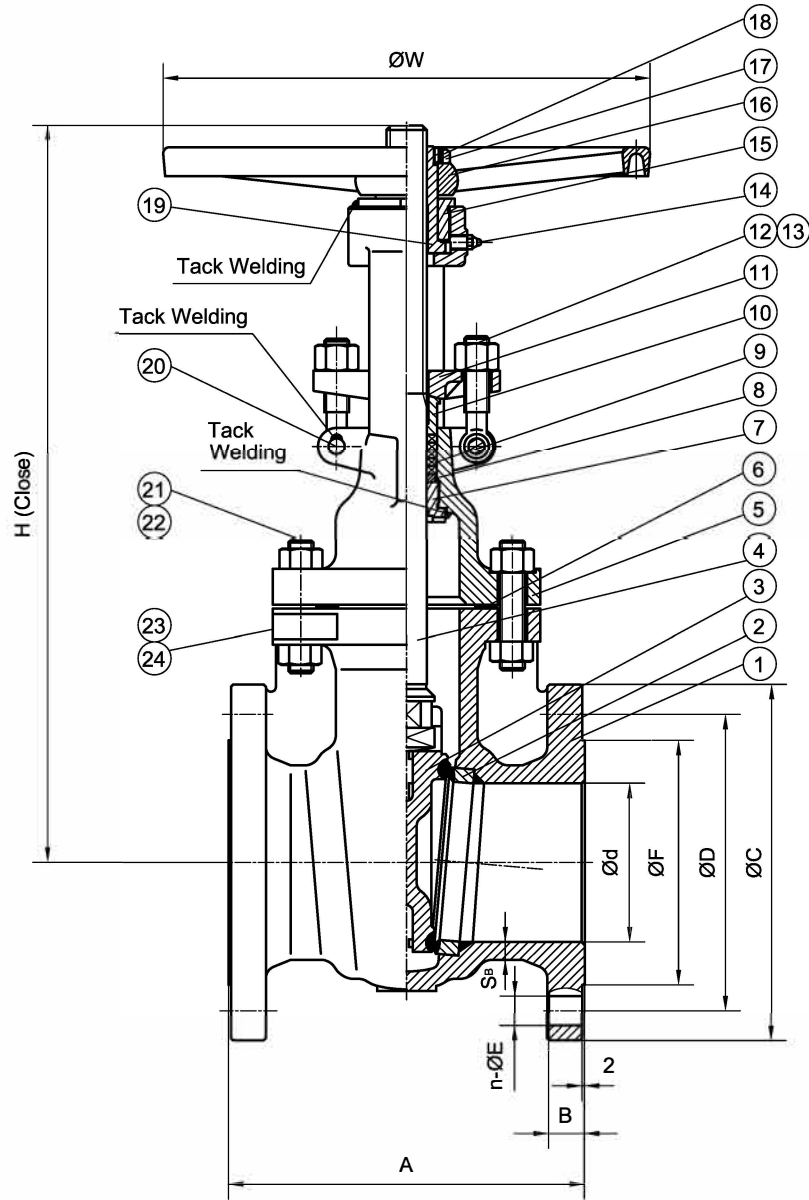

ITEM	NAME	MATERIAL
1	BODY	ASTM A216-WCB
2	SEAT	ASTM A105N+STL
3	FLEXIBLE WEDGE	ASTM A216-WCB+13%Cr
4	STEM	ASTM A182-F6a
5	BONNET	ASTM A216-WCB
6	GASKET	304+GRAPHITE
7	BACKSEAT	ASTM A276-420
8	PACKING SPACER	ASTM A276-410
9	PACKING	INCONEL600+GRAPHITE
10	GLAND	ASTM A276-410
11	GLAND FLANGE	ASTM A216-WCB
12	EYE BOLT	ASTM A193-B7
13	NUT	ASTM A194-2H
14	GREASE FITTING	ASTM A283 GRC
15	GLAND NUT	AISI 1025
16	HANDWHEEL	ASTM A536 60-40-18
17	HANDWHEEL NUT	AISI 1025
18	SCREW	AISI 1025
19	STEM NUT	ASTM A439 D-2
20	PIN	AISI 1035
21	BOLT	ASTM A193-B7
22	NUT	ASTM A194-2H
23	NAMEPLATE	ASTM A240-304
24	RIVET	ASTM A240-304

NOTE:

1. FLEXIBLE WEDGE
2. API 624 QUALIFIED

ITEM	FIG NO.	SIZE	UNIT	d	A	B	C	D	n	E	F	H	W	S <sub>b</sub>	Weight(lbs/kgs)
01	GT150CSF8	5"	mm	127	254	24.3	255	215.9	8	22	185.7	538	300	11.9	141/64
		5"	in	5.0	10.0	0.96	10.0	8.5	8	7/8	7.31	21.18	11.81	0.47	
02	GT150CSF8	6"	mm	152	267	25.9	280	241.3	8	22	215.9	600	300	11.9	176/80
		6"	in	6.0	10.5	1.02	11.0	9.5	8	7/8	8.5	23.62	11.81	0.47	
03	GT150CSF8	8"	mm	203	292	29	345	298.5	8	22	269.9	740	350	12.7	256/116
		8"	in	8.0	11.5	1.14	13.5	11.75	8	7/8	10.62	29.13	13.78	0.5	
04	GT150CSF8	10"	mm	254	330	30.6	405	362	12	25	323.8	883	400	14.2	397/180
		10"	in	10.0	13.0	1.2	16.0	14.25	12	1	12.75	34.76	15.75	0.56	
05	GT150CSF8	12"	mm	305	356	32.2	485	431.8	12	25	381.0	1020	450	16	560/254
		12"	in	12.0	14.0	1.27	19.0	17.0	12	1	15.0	40.16	17.7	0.63	



**J.J. VALVE**  
Toll Free 800.582.5837 Local 310.605.0090

Here at J.J. Valve, we utilize a wide variety of products to meet your needs when it comes to industrial valves.

TITLE:		CAST STEEL GATE VALVE	
		CLASS 150- API TRIM 8 - RF - HANDWHEEL OPERATED	
MATERIAL: ASTM A216 WCB	UNITS: Inch, mm		
CLASS: 150	DATE: 4/15/19	SCALE: N.T.S.	
SIZE: 5"-12"	DRAWN BY: F.J.		FIG. No.: <b>GT150CSF8</b>
CHK'D & APR'D BY: E.C.	REV: 1	DWG No.:	

					MARKING SYSTEM	MSS-SP-25	INSPECTION & TEST: API 598			MATERIAL: ASTM A216 WCB	UNITS: Inch, mm	
					DIM.OF FLANGE	ANSI B16.5	SHELL	HYDRO	450PSI	CLASS: 150	DATE: 4/15/19	SCALE: N.T.S.
					FACE TO FACE	ANSI B16.10	SEAT	AIR	80PSI	SIZE: 5"-12"	FIG. No.: <b>GT150CSF8</b>	
					WALL THICKNESS	API 600	BACK SEAT	HYDRO	315PSI	DRAWN BY: F.J.		
					DESIGNED	API 600, ANSI B16.34				CHK'D & APR'D BY: E.C.	REV: 1	DWG No.:

4/15/19	RELEASED	F.J.	E.C.	E.C.	
NO.	DATE	DESCRIPTION	PRPD	REV'D	APP'D

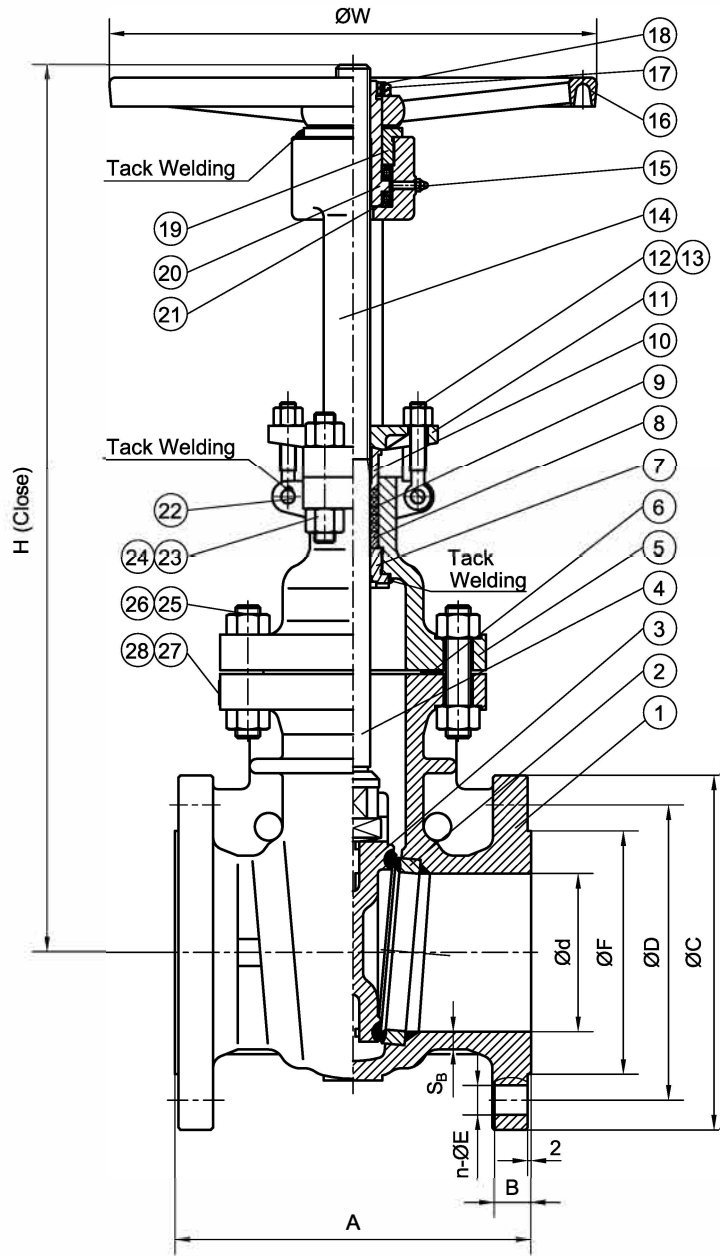

ITEM	NAME	MATERIAL
1	BODY	ASTM A216-WCB
2	SEAT	ASTM A105N+STL
3	FLEXIBLE WEDGE	ASTM A216-WCB+13%Cr
4	STEM	ASTM A182-F6a
5	BONNET	ASTM A216-WCB
6	GASKET	304+GRAPHITE
7	BACKSEAT	ASTM A276-420
8	PACKING SPACER	ASTM A276-410
9	PACKING	INCONEL600+GRAPHITE
10	GLAND	ASTM A276-410
11	GLAND FLANGE	ASTM A216-WCB
12	EYE BOLT	ASTM A193-B7
13	NUT	ASTM A194-2H
14	YOKE	ASTM A216-WCB
15	GREASE FITTING	ASTM A283 GRC
16	HANDWHEEL	ASTM A536 60-40-18
17	HANDWHEEL NUT	AISI 1025
18	SCREW	AISI 1025
19	GLAND NUT	AISI 1025
20	STEM NUT	ASTM A439 D-2
21	BEARING	AISI 52100
22	PIN	AISI 1035
23	BOLT	ASTM A193-B7
24	NUT	ASTM A194-2H
25	BOLT	ASTM A193-B7
26	NUT	ASTM A194-2H
27	NAMEPLATE	ASTM A240-304
28	RIVET	ASTM A240-304

NOTE:  
 1. FLEXIBLE WEDGE  
 2. API 624 QUALIFIED

ITEM	FIG NO.	SIZE	UNIT	d	A	B	C	D	n	E	F	H	W	Ss	Weight(lbs/kgs)
01	GT150CSF8	14"	mm	337	381	35.4	535	476.3	12	29	412.8	1157	500	16.8	893/405
		14"	in	13.27	15.0	1.39	21.0	18.75	12	1-1/8	16.25	45.55	19.69	0.66	

				MARKING SYSTEM	MSS-SP-25	INSPECTION & TEST: API 598			MATERIAL: ASTM A216 WCB		UNITS: Inch, mm	
				DIM.OF FLANGE	ANSI B16.5	SHELL	HYDRO	450PSI	CLASS: 150	DATE: 4/15/19	SCALE: N.T.S.	
				FACE TO FACE	ANSI B16.10	SEAT	AIR	80PSI	SIZE: 14"	FIG. No.:		
				WALL THICKNESS	API 600	BACK SEAT	HYDRO	315PSI	DRAWN BY: F.J.		<b>GT150CSF8</b>	
NO.	DATE	DESCRIPTION	PRP'D	REV'D	APP'D	DESIGNED	API 600, ANSI B16.34	CHK'D & APR'D BY: E.C.		REV: 1	DWG No.:	



**J.J. VALVE**  
 Toll Free 800.582.5837 Local 310.605.0090

Here at J.J. Valve, we utilize a wide variety of products to meet your needs when it comes to industrial valves.

TITLE: CAST STEEL GATE VALVE  
 CLASS 150- API TRIM 8 - RF - HANDWHEEL OPERATED









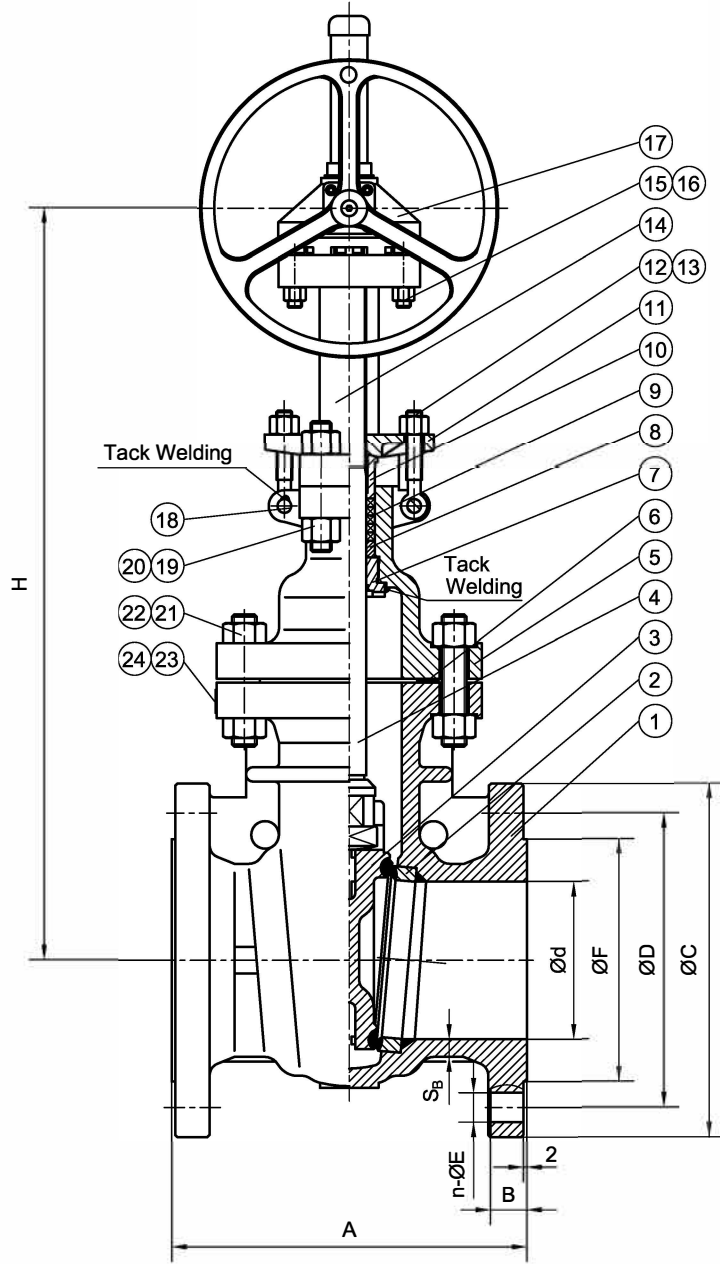

ITEM	NAME	MATERIAL
1	BODY	ASTM A216-WCB
2	SEAT	ASTM A105N+STL
3	FLEXIBLE WEDGE	ASTM A216-WCB+13%Cr
4	STEM	ASTM A182-F6a
5	BONNET	ASTM A216-WCB
6	GASKET	304+GRAPHITE
7	BACKSEAT	ASTM A276-420
8	PACKING SPACER	ASTM A276-410
9	PACKING	INCONEL600+GRAPHITE
10	GLAND	ASTM A276-410
11	GLAND FLANGE	ASTM A216-WCB
12	EYE BOLT	ASTM A193-B7
13	NUT	ASTM A194-2H
14	YOKE	ASTM A216-WCB
15	BOLT	ASTM A193-B7
16	NUT	ASTM A194-2H
17	GEAR	ASTM A216-WCB
18	PIN	AISI 1035
19	BOLT	ASTM A193-B7
20	NUT	ASTM A194-2H
21	BOLT	ASTM A193-B7
22	NUT	ASTM A194-2H
23	NAMEPLATE	ASTM A240-304
24	RIVET	ASTM A240-304

NOTE:  
 1. FLEXIBLE WEDGE  
 2. API 624 QUALIFIED

ITEM	FIG NO.	SIZE	UNIT	d	A	B	C	D	n	E	F	H	W	K	S <sub>b</sub>	Weight(lbs/kgs)
01	GT150CSF8	14"	mm	337	381	35.4	535	476.3	12	29	412.8	1165	460	345	16.8	893/405
		14"	in	13.27	15.0	1.39	21.0	18.75	12	1-1/8	16.25	45.87	18.1	13.58	0.66	

				MARKING SYSTEM	MSS-SP-25	INSPECTION & TEST: API 598			MATERIAL: ASTM A216 WCB			UNITS: Inch, mm			
				DIM.OF FLANGE	ANSI B16.5	SHELL	HYDRO	450PSI	CLASS: 150	DATE: 4/15/19	SCALE: N.T.S.				
				FACE TO FACE	ANSI B16.10	SEAT	AIR	80PSI	SIZE: 14"	FIG. No.: GT150CSF8-BG					
				WALL THICKNESS	API 600	BACK SEAT	HYDRO	315PSI	DRAWN BY: F.J.						
				NO.	DATE	DESCRIPTION	PRP'D	REV'D	APP'D	DESIGNED	API 600, ANSI B16.34	CHK'D & APR'D BY: E.C.		REV: 1	DWG No.:

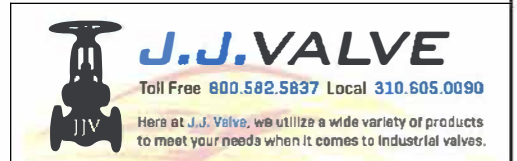

TITLE: CAST STEEL GATE VALVE  
 CLASS 150- API TRIM 8 - RF - GEAR OPERATED

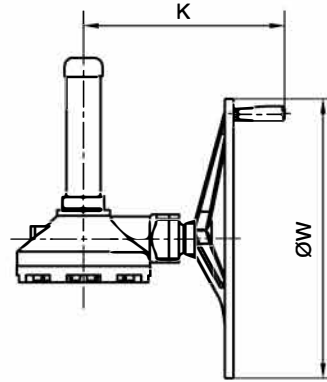
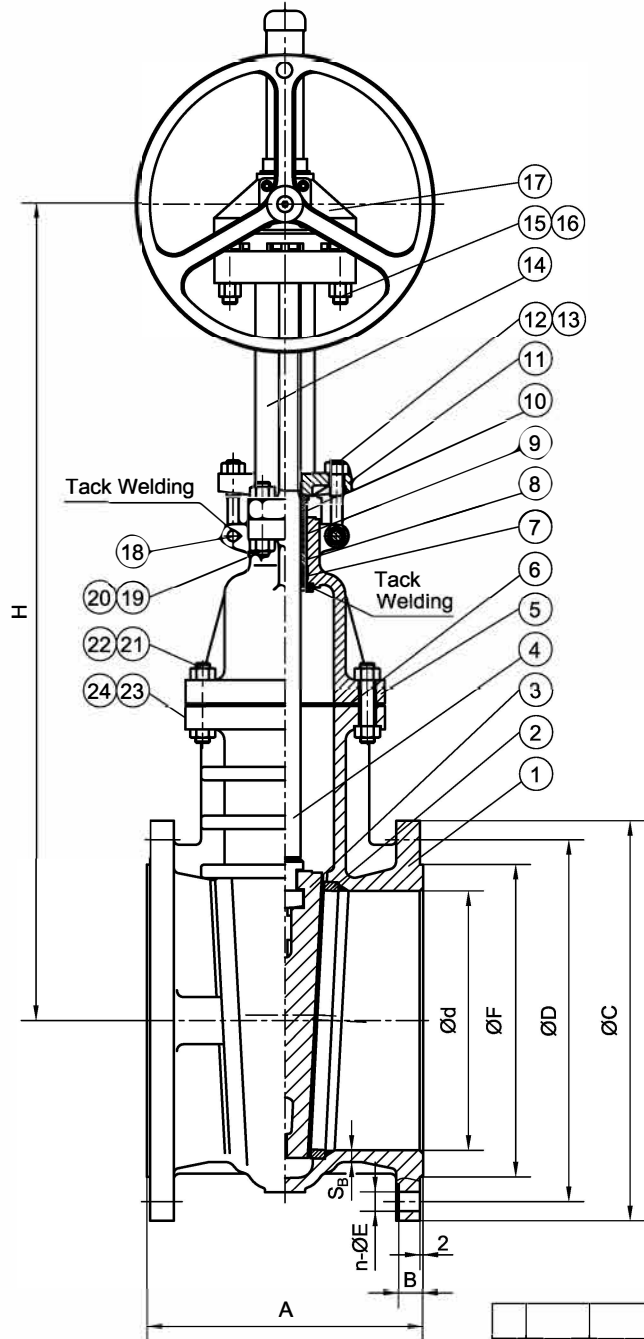

ITEM	NAME	MATERIAL
1	BODY	ASTM A216-WCB
2	SEAT	ASTM A105N+STL
3	FLEXIBLE WEDGE	ASTM A216-WCB+13%Cr
4	STEM	ASTM A182-F6a
5	BONNET	ASTM A216-WCB
6	GASKET	304+GRAPHITE
7	BACKSEAT	ASTM A276-420
8	PACKING SPACER	ASTM A276-410
9	PACKING	INCONEL600+GRAPHITE
10	GLAND	ASTM A276-410
11	GLAND FLANGE	ASTM A216-WCB
12	EYE BOLT	ASTM A193-B7
13	NUT	ASTM A194-2H
14	YOKE	ASTM A216-WCB
15	BOLT	ASTM A193-B7
16	NUT	ASTM A194-2H
17	GEAR	ASTM A216-WCB
18	PIN	AISI 1035
19	BOLT	ASTM A193-B7
20	NUT	ASTM A194-2H
21	BOLT	ASTM A193-B7
22	NUT	ASTM A194-2H
23	NAMEPLATE	ASTM A240-304
24	RIVET	ASTM A240-304

NOTE:

1. FLEXIBLE WEDGE
2. API 624 QUALIFIED

ITEM	FIG NO.	SIZE	UNIT	d	A	B	C	D	n	E	F	H	W	K	S <sub>B</sub>	Weight(lbs/kgs)
01	GT150CSF8	16"	mm	387	406	37	595	539.8	16	29	469.9	1300	460	345	17.5	1146/520
		16"	in	15.24	16.0	1.46	23.5	21.25	16	1-1/8	18.5	51.18	18.1	13.58	0.69	
02	GT150CSF8	18"	mm	438	432	40.1	635	577.9	16	32	533.4	1439	610	420	18.3	1407/638
		18"	in	17.24	17.0	1.58	25.0	22.75	16	1-1/4	21.0	56.65	24.02	16.54	0.72	

				MARKING SYSTEM	MSS-SP-25	INSPECTION & TEST: API 598			MATERIAL: ASTM A216 WCB			UNITS: Inch, mm	
				DIM.OF FLANGE	ANSI B16.5	SHELL	HYDRO	450PSI	CLASS: 150	DATE: 4/15/19	SCALE: N.T.S.		
				FACE TO FACE	ANSI B16.10	SEAT	AIR	80PSI	SIZE: 16"-18"			FIG. No.: GT150CSF8-BG	
				WALL THICKNESS	API 600	BACK SEAT	HYDRO	315PSI	DRAWN BY: F.J.			CHK'D & APR'D BY: E.C. REV: 1	
NO.	DATE	DESCRIPTION	PRP'D	REV'D	APPD	DESIGNED	API 600, ANSI B16.34		DWG No.:				



**J.J. VALVE**  
Toll Free 800.582.5837 Local 310.605.0090

Here at J.J. Valve, we utilize a wide variety of products to meet your needs when it comes to industrial valves.

TITLE: CAST STEEL GATE VALVE  
CLASS 150- API TRIM 8 - RF - GEAR OPERATED



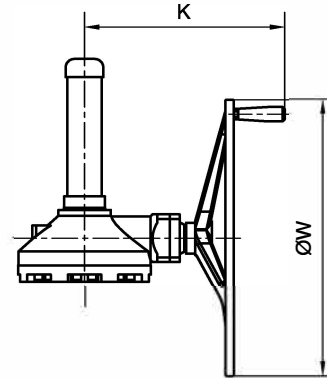
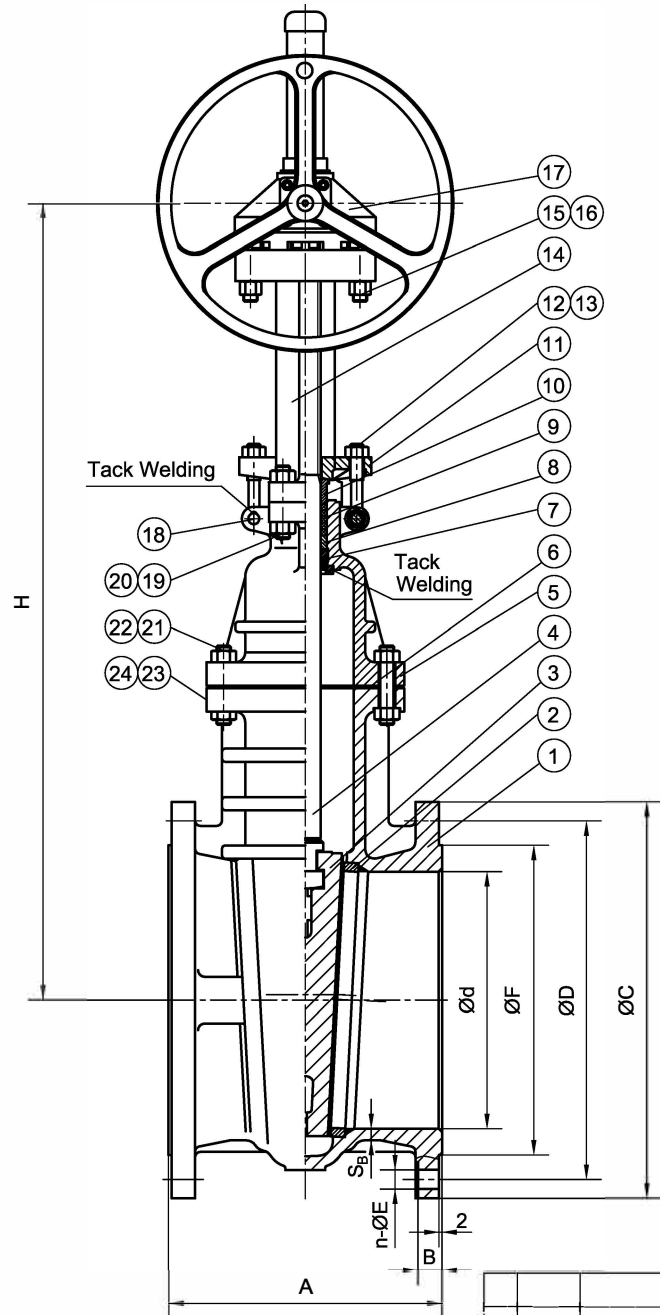

ITEM	NAME	MATERIAL
1	BODY	ASTM A216-WCB
2	SEAT	ASTM A105N+STL
3	FLEXIBLE WEDGE	ASTM A216-WCB+13%Cr
4	STEM	ASTM A182-F6a
5	BONNET	ASTM A216-WCB
6	GASKET	304+GRAPHITE
7	BACKSEAT	ASTM A276-420
8	PACKING SPACER	ASTM A276-410
9	PACKING	INCONEL600+GRAPHITE
10	GLAND	ASTM A276-410
11	GLAND FLANGE	ASTM A216-WCB
12	EYE BOLT	ASTM A193-B7
13	NUT	ASTM A194-2H
14	YOKE	ASTM A216-WCB
15	BOLT	ASTM A193-B7
16	NUT	ASTM A194-2H
17	GEAR	ASTM A216-WCB
18	PIN	AISI 1035
19	BOLT	ASTM A193-B7
20	NUT	ASTM A194-2H
21	BOLT	ASTM A193-B7
22	NUT	ASTM A194-2H
23	NAMEPLATE	ASTM A240-304
24	RIVET	ASTM A240-304

NOTE:

- 1. FLEXIBLE WEDGE
- 2. API 624 QUALIFIED

ITEM	FIG NO.	SIZE	UNIT	d	A	B	C	D	n	E	F	H	W	K	S <sub>B</sub>	Weight(lbs/kgs)
01	GT150CSF8	20"	mm	489	457	43.3	700	635	20	32	584.2	1596	610	420	19.1	1720/780
		20"	in	19.25	18.0	1.70	27.5	25.0	20	1-1/4	23.0	62.83	24.02	16.54	0.75	
02	GT150CSF8	24"	mm	591	508	48.1	815	749.3	20	35	692.2	1860	610	420	20.6	2443/1108
		24"	in	23.27	20.0	1.90	32.0	29.5	20	1-3/8	27.25	73.23	24.02	16.54	0.81	



## J.J. VALVE

Toll Free 800.582.5837 Local 310.605.0090

Here at J.J. Valve, we utilize a wide variety of products to meet your needs when it comes to industrial valves.

TITLE: CAST STEEL GATE VALVE  
CLASS 150- API TRIM 8 - RF - GEAR OPERATED

MARKING SYSTEM	MSS-SP-25	INSPECTION & TEST: API 598	MATERIAL: ASTM A216 WCB	UNITS: Inch, mm
DIM.OF FLANGE	ANSI B16.5	SHELL HYDRO 450PSI	CLASS: 150	DATE: 4/15/19
FACE TO FACE	ANSI B16.10	SEAT AIR 80PSI	SIZE: 20"-24"	SCALE: N.T.S.
WALL THICKNESS	API 600	BACK SEAT HYDRO 315PSI	DRAWN BY: F.J.	FIG. No.: GT150CSF8-BG
DESIGNED	API 600, ANSI B16.34		CHK'D & APR'D BY: E.C.	REV: 1

4/15/19	RELEASED	F.J.	E.C.	E.C.					
NO.	DATE	DESCRIPTION	PRP'D	REV'D	APP'D	DESIGNED			

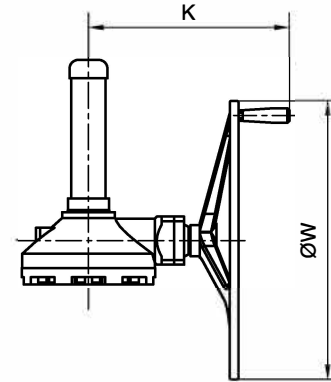
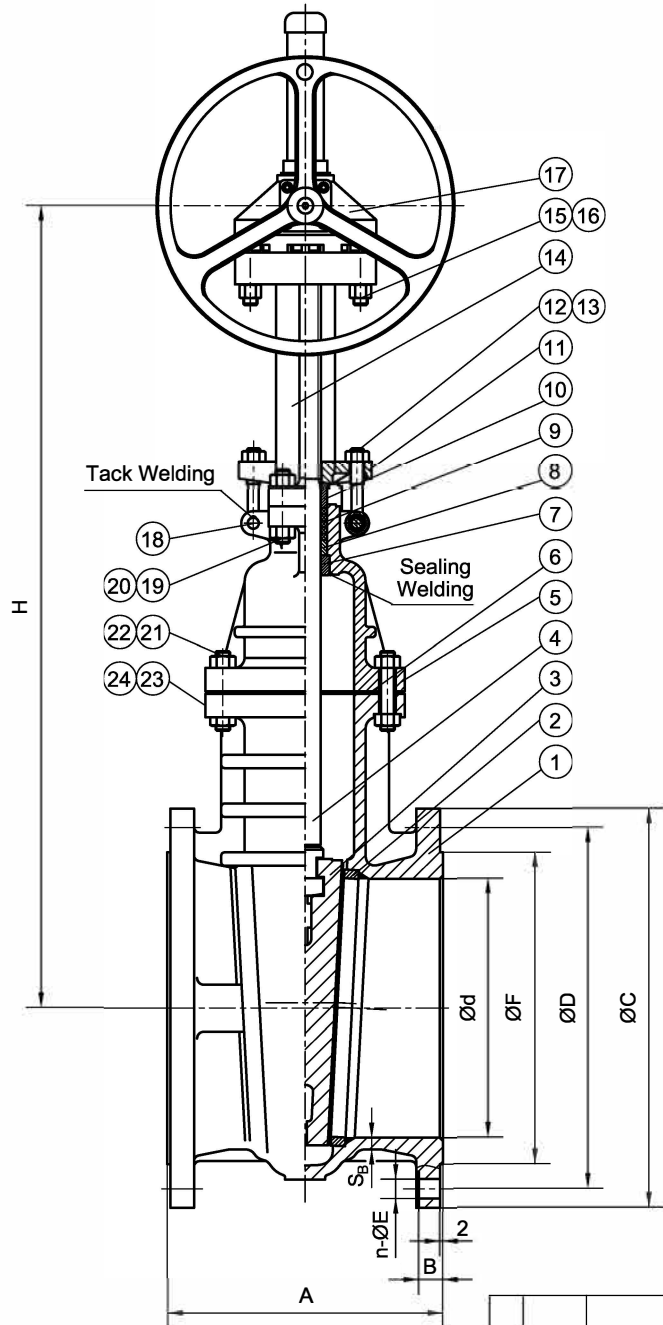

ITEM	NAME	MATERIAL
1	BODY	ASTM A216-WCB
2	SEAT	ASTM A105N+STL
3	FLEXIBLE WEDGE	ASTM A216-WCB+13%Cr
4	STEM	ASTM A182-F6a
5	BONNET	ASTM A216-WCB
6	GASKET	304+GRAPHITE
7	BACKSEAT	ASTM A276-420
8	PACKING SPACER	ASTM A276-410
9	PACKING	INCONEL600+GRAPHITE
10	GLAND	ASTM A276-410
11	GLAND FLANGE	ASTM A216-WCB
12	EYE BOLT	ASTM A193-B7
13	NUT	ASTM A194-2H
14	YOKE	ASTM A216-WCB
15	BOLT	ASTM A193-B7
16	NUT	ASTM A194-2H
17	GEAR	ASTM A216-WCB
18	PIN	AISI 1035
19	BOLT	ASTM A193-B7
20	NUT	ASTM A194-2H
21	BOLT	ASTM A193-B7
22	NUT	ASTM A194-2H
23	NAMEPLATE	ASTM A240-304
24	RIVET	ASTM A240-304

NOTE:

1. API 622 LOW EMISSION PACKING

ITEM	FIG NO.	SIZE	UNIT	d	A	B	C	D	n	E	F	H	W	K	S <sub>b</sub>	Weight(lbs/kgs)
01	GT150CSF8	30"	mm	743	610	75.1	985	914.4	28	35	857	2325	710	500	23	4486/2035
		30"	in	29.25	24.0	2.95	38.75	36.0	28	1-3/8	33.75	91.54	27.95	19.69	0.91	
02	GT150CSF8	36"	mm	876	711	90.9	1170	1085.8	32	41	1022	2689	800	610	25.3	7451/3380
		36"	in	34.49	28.0	3.58	46.06	42.75	32	1-5/8	40.24	105.87	31.5	24.0	1.00	
03	GT150CSF8	42"	mm	1022	787	97.3	1345	1257.3	36	41	1194	3173	800	610	27.7	11684/5300
		42"	in	40.24	31.0	3.83	53.0	49.5	36	1-5/8	47.0	124.92	31.5	24.0	1.09	



**J.J. VALVE**  
Toll Free 800.582.5837 Local 310.605.0090

Here at J.J. Valve, we utilize a wide variety of products to meet your needs when it comes to industrial valves.

TITLE: CAST STEEL GATE VALVE  
CLASS 150- API TRIM 8 - RF - GEAR OPERATED

MATERIAL: ASTM A216 WCB	UNITS: Inch, mm
CLASS: 150	DATE: 4/15/19
SCALE: N.T.S.	FIG. No.: N.T.S.
SIZE: 30"-42"	FIG. No.: GT150CSF8-BG
DRAWN BY: F.J.	CHK'D & APR'D BY: E.C.
REV: 1	DWG No.:

NO.	DATE	DESCRIPTION	PRPD	REV'D	APP'D	DESIGNED
△	4/15/19	RELEASED	F.J.	E.C.	E.C.	

MARKING SYSTEM	MSS-SP-25	INSPECTION & TEST:	API 598
DIM.OF FLANGE	ANSI B16.47A	SHELL	HYDRO 450PSI
FACE TO FACE	ANSI B16.10	SEAT	AIR 80PSI
WALL THICKNESS	API 600	BACK SEAT	HYDRO 315PSI
	API 600, ANSI B16.34		

MATERIAL: ASTM A216 WCB	UNITS: Inch, mm
CLASS: 150	DATE: 4/15/19
SCALE: N.T.S.	FIG. No.: N.T.S.
SIZE: 30"-42"	FIG. No.: GT150CSF8-BG
DRAWN BY: F.J.	CHK'D & APR'D BY: E.C.
REV: 1	DWG No.: