

3 Ribs uniformly distributed in circumference

ITEM	NAME	MATERIAL
1	BODY	ASTM A216-WCB
2	SEAT	ASTM A105N+STL
3	DISC WASHER	ASTM A276-420
4	DISC	ASTM A105N+13%Cr
5	DISC BUSHING	ASTM A276-410
6	GASKET	304+GRAPHITE
7	STEM	ASTM A182-F6a
8	BONNET	ASTM A216-WCB
9	BACKSEAT	ASTM A276-420+STL
10	PACKING SPACER	ASTM A276-410
11	PACKING	INCONEL600+GRAPHITE
12	GLAND	ASTM A276-410
13	GLAND FLANGE	ASTM A216-WCB
14	EYE BOLT	ASTM A193-B7
15	NUT	ASTM A194-2H
16	STEM NUT	ASTM A439 D-2
17	SCREW	AISI 1025
18	WASHER	ASTM A283 GRC
19	NUT	ASTM A194-2H
20	HANDWHEEL	ASTM A536 60-40-18
21	PIN	AISI 1035
22	BOLT	ASTM A193-B7
23	NUT	ASTM A194-2H
24	NAMEPLATE	ASTM A240-304
25	RIVET	ASTM A240-304

NOTE:

1. API 622 LOW EMISSION PACKING

ITEM	FIG NO.	SIZE	UNIT	d	A	B	C	D	n	E	F	H	W	Sa	Weight(lbs/kgs)
01	GL150CSF8	2"	mm	51	203	16.3	150	120.7	4	19	92.1	328	200	8.6	55/25
		2"	in	2.0	8.0	0.64	6.0	4.75	4	3/4	3.62	12.91	7.87	0.34	
02	GL150CSF8	2-1/2"	mm	64	216	17.9	180	139.7	4	19	104.8	340	250	9.7	64/29
		2-1/2"	in	2.5	8.5	0.7	7.0	5.5	4	3/4	4.12	13.39	9.84	0.38	
03	GL150CSF8	3"	mm	76	241	19.5	190	152.4	4	19	127	351	250	10.4	101/46
		3"	in	3.0	9.5	0.77	7.5	6.0	4	3/4	5.0	13.82	9.84	0.41	
04	GL150CSF8	4"	mm	102	292	24.3	230	190.5	8	19	157.2	440	300	11.2	128/58
		4"	in	4.0	11.5	0.96	9.0	7.5	8	3/4	6.19	17.32	11.81	0.44	
05	GL150CSF8	5"	mm	127	356	24.3	255	215.9	8	22	185.7	451	350	11.9	198/90
		5"	in	5.0	14.0	0.96	10.0	8.5	8	7/8	7.31	17.76	13.78	0.47	
06	GL150CSF8	6"	mm	152	406	25.9	280	241.3	8	22	215.9	468	350	11.9	229/104
		6"	in	6.0	16.0	1.02	11.0	9.5	8	7/8	8.5	18.43	13.78	0.47	

**J.J. VALVE**  
Toll Free 800.582.5837 Local 310.605.0090  
Here at J.J. Valve, we utilize a wide variety of products to meet your needs when it comes to industrial valves.

TITLE: CAST STEEL GLOBE VALVE  
CLASS 150- API TRIM 8 -RF- HANDWHEEL OPERATED

MARKING SYSTEM	MSS-SP-25	INSPECTION & TEST:	API 598	MATERIAL:	ASTM A216 WCB	UNITS:	Inch, mm
DIM.OF FLANGE	ANSI B16.5	SHELL	HYDRO 450PSI	CLASS:	150	DATE:	4/15/19
FACE TO FACE	ANSI B16.10	SEAT	AIR N/A	SIZE:	2"-6"	SCALE:	N.T.S.
WALL THICKNESS	API 623	BACK SEAT	HYDRO 315PSI	DRAWN BY:	F.J.	FIG. No.:	GL150CSF8
NO.	DATE	DESCRIPTION	PRPD	REV'D	APP'D	DESIGNED	API 623, ANSI B16.34
CHKD & APR'D BY: E.C.				REV: 1	DWG No.:		

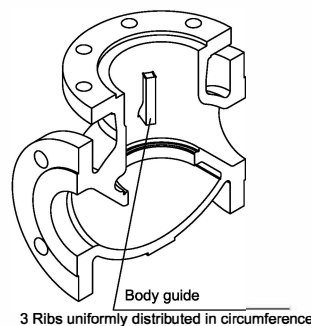
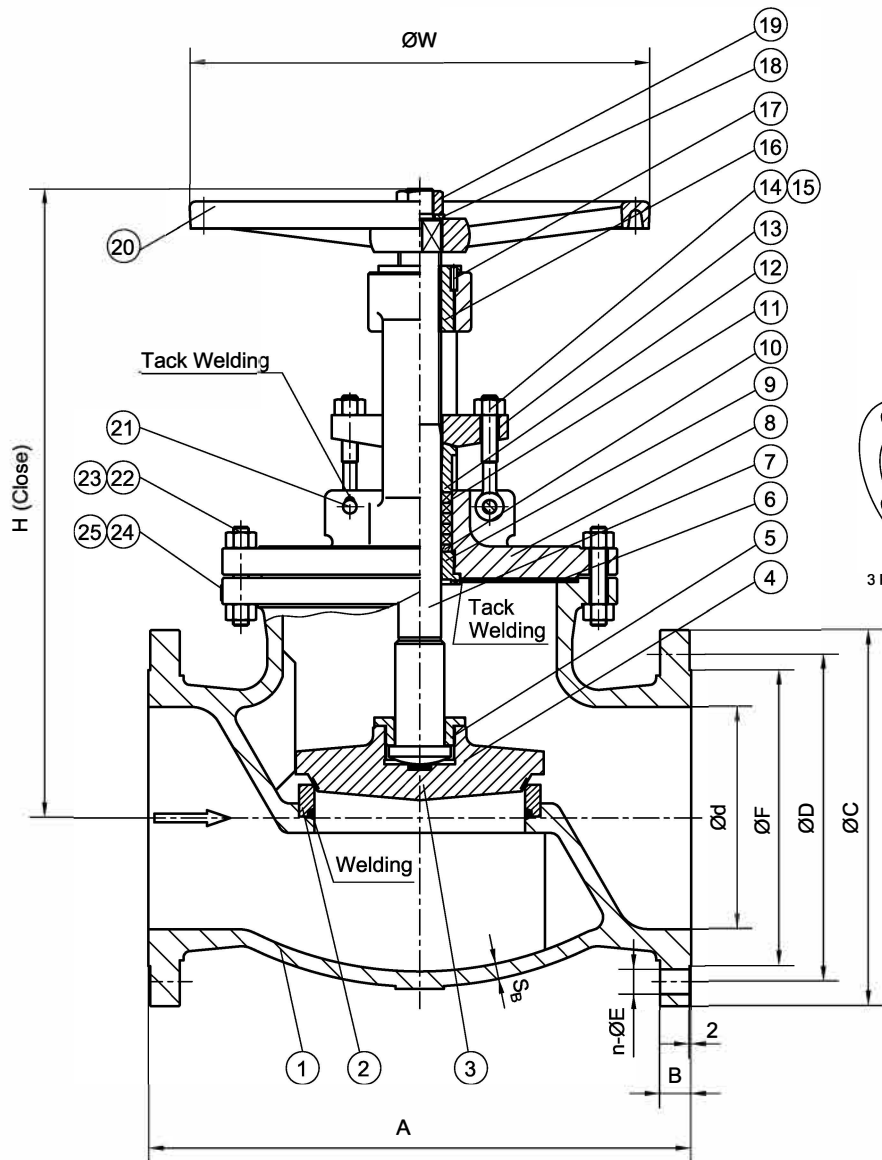

ITEM	NAME	MATERIAL
1	BODY	ASTM A216-WCB
2	SEAT	ASTM A105N+STL
3	DISC WASHER	ASTM A276-420
4	DISC	ASTM A105N+13%Cr
5	DISC BUSHING	ASTM A276-410
6	GASKET	304+GRAPHITE
7	STEM	ASTM A182-F6a
8	BONNET	ASTM A216-WCB
9	BACKSEAT	ASTM A276-420+STL
10	PACKING SPACER	ASTM A276-410
11	PACKING	INCONEL600+GRAPHITE
12	GLAND	ASTM A276-410
13	GLAND FLANGE	ASTM A216-WCB
14	EYE BOLT	ASTM A193-B7
15	NUT	ASTM A194-2H
16	STEM NUT	ASTM A439 D-2
17	SCREW	AISI 1025
18	WASHER	ASTM A283 GRC
19	NUT	ASTM A194-2H
20	HANDWHEEL	ASTM A536 60-40-18
21	PIN	AISI 1035
22	BOLT	ASTM A193-B7
23	NUT	ASTM A194-2H
24	NAMEPLATE	ASTM A240-304
25	RIVET	ASTM A240-304

NOTE:  
1. API 622 LOW EMISSION PACKING

ITEM	FIG NO.	SIZE	UNIT	d	A	B	C	D	n	E	F	H	W	S <sub>b</sub>	Weight(lbs/kgs)
01	GL150CSF8	8"	mm	203	495	29	345	298.5	8	22	269.9	545	450	12.7	348/158
		8"	in	8.0	19.5	1.14	13.5	11.75	8	7/8	10.62	21.46	17.72	0.5	



**J.J. VALVE**  
Toll Free 800.582.5837 Local 310.605.0080

Here at J.J. Valve, we utilize a wide variety of products to meet your needs when it comes to industrial valves.

TITLE: CAST STEEL GLOBE VALVE  
CLASS 150- API TRIM 8 -RF- HANDWHEEL OPERATED

MARKING SYSTEM	MSS-SP-25	INSPECTION & TEST:	API 598	MATERIAL:	ASTM A216 WCB	UNITS:	Inch, mm
DIM.OF FLANGE	ANSI B16.5	SHELL	HYDRO	450PSI	CLASS: 150	DATE:	4/15/19
FACE TO FACE	ANSI B16.10	SEAT	AIR	N/A	SIZE: 8"	SCALE: N.T.S.	
WALL THICKNESS	API 623	BACK SEAT	HYDRO	315PSI	DRAWN BY:	F.J.	
NO.	DATE	DESCRIPTION	PRP'D	REV'D	APP'D	DESIGNED	API 623, ANSI B16.34
						CHK'D & APR'D BY:	E.C. REV: 1
						DWG No.:	GL150CSF8

4/15/19	RELEASED	F.J.	E.C.	E.C.			
NO.	DATE	DESCRIPTION	PRP'D	REV'D	APP'D	DESIGNED	API 623, ANSI B16.34

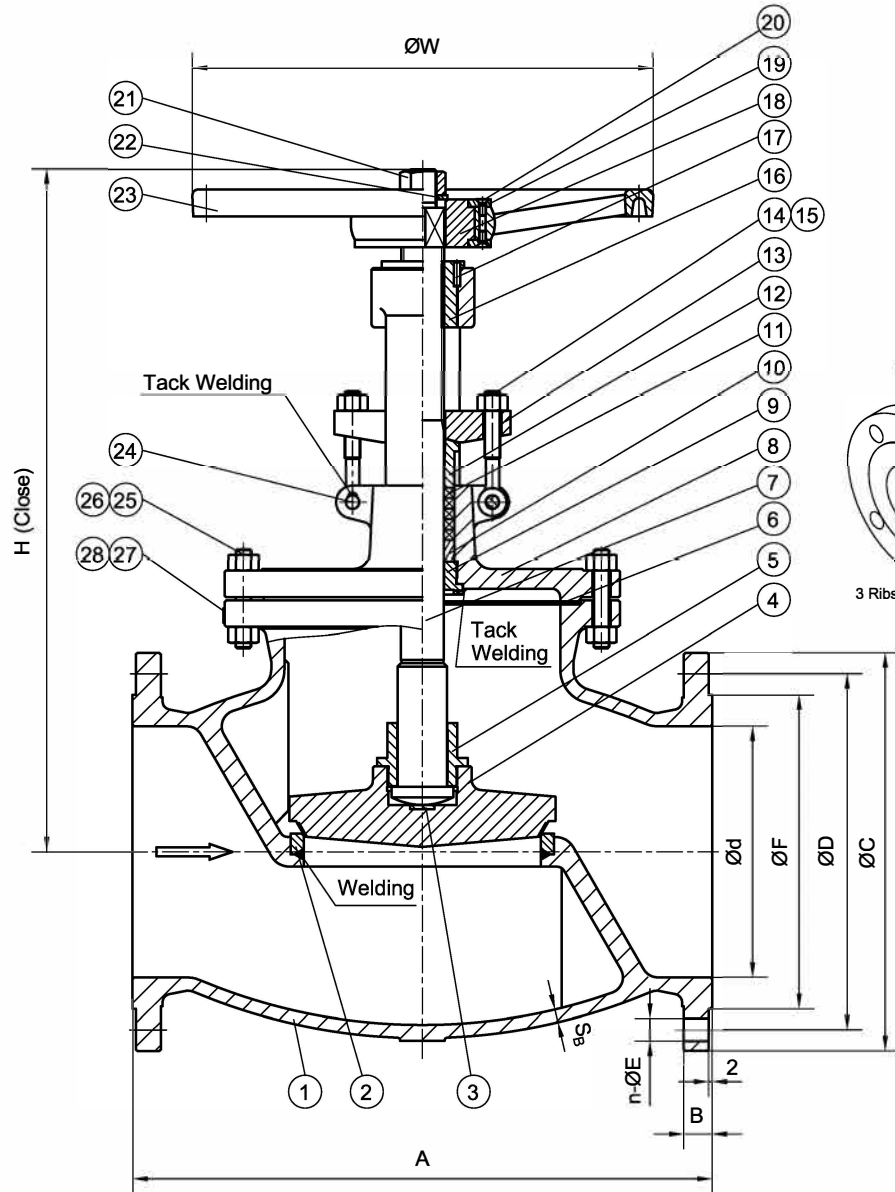

ITEM	NAME	MATERIAL
1	BODY	ASTM A216-WCB
2	SEAT	ASTM A105N+STL
3	DISC WASHER	ASTM A276-420
4	DISC	ASTM A105N+13%Cr
5	DISC BUSHING	ASTM A276-410
6	GASKET	304+GRAPHITE
7	STEM	ASTM A182-F6a
8	BONNET	ASTM A216-WCB
9	BACKSEAT	ASTM A276-420+STL
10	PACKING SPACER	ASTM A276-410
11	PACKING	INCONEL600+GRAPHITE
12	GLAND	ASTM A276-410
13	GLAND FLANGE	ASTM A216-WCB
14	EYE BOLT	ASTM A193-B7
15	NUT	ASTM A194-2H
16	STEM NUT	ASTM A439 D-2
17	SCREW	AISI 1025
18	HAMMER BLOCK	AISI 1045
19	COVER PLATE	AISI 1035
20	COUNTERSUNK BOLT	AISI 1035
21	NUT	ASTM A194-2H
22	WASHER	ASTM A283 GRC
23	HANDWHEEL	ASTM A536 60-40-18
24	PIN	AISI 1035
25	BOLT	ASTM A193-B7
26	NUT	ASTM A194-2H
27	NAMEPLATE	ASTM A240-304
28	RIVET	ASTM A240-304

NOTE:  
1. API 622 LOW EMISSION PACKING

ITEM	FIG NO.	SIZE	UNIT	d	A	B	C	D	n	E	F	H	W	S <sub>b</sub>	Weight(lbs/kgs)
01	GL150CSF8	10"	mm	254	622	30.6	405	362	12	25	323.8	630	500	14.2	608/276
		10"	in	10.0	24.5	1.2	16.0	14.25	12	1	12.75	24.8	19.69	0.56	
02	GL150CSF8	12"	mm	305	698	32.2	485	431.8	12	25	381	822	560	16	1069/485
		12"	in	12.0	27.5	1.27	19.0	17.00	12	1	15.00	32.36	22.05	0.63	
03	GL150CSF8	14"	mm	337	787	35.4	535	476.3	12	29	412.8	873	560	16.8	1213/550
		14"	in	13.27	31.0	1.39	21.0	18.75	12	1-1/8	16.25	34.37	22.05	0.66	



**J.J. VALVE**  
Toll Free 800.582.5837 Local 310.605.0090

Here at J.J. Valve, we utilize a wide variety of products to meet your needs when it comes to industrial valves.

TITLE:		CAST STEEL GLOBE VALVE	
		CLASS 150- API TRIM 8 -RF- HANDWHEEL OPERATED	
MATERIAL: ASTM A216 WCB	UNITS: Inch, mm	DATE: 4/15/19	SCALE: N.T.S.
CLASS: 150	SIZE: 10"-14"	FIG. No.: <b>GL150CSF8</b>	
DRAWN BY: F.J.	CHK'D & APR'D BY: E.C.	REV: 1	DWG No.:

MARKING SYSTEM	MSS-SP-25	INSPECTION & TEST:	API 598
DIM.OF FLANGE	ANSI B16.5	SHELL	HYDRO 450PSI
FACE TO FACE	ANSI B16.10	SEAT	AIR N/A
WALL THICKNESS	API 623	BACKSEAT	HYDRO 315PSI
DESIGNED	API 623, ANSI B16.34		

NO.	DATE	DESCRIPTION	PRPD	REV'D	APP'D
▲	4/15/19	RELEASED			F.J. E.C. E.C.

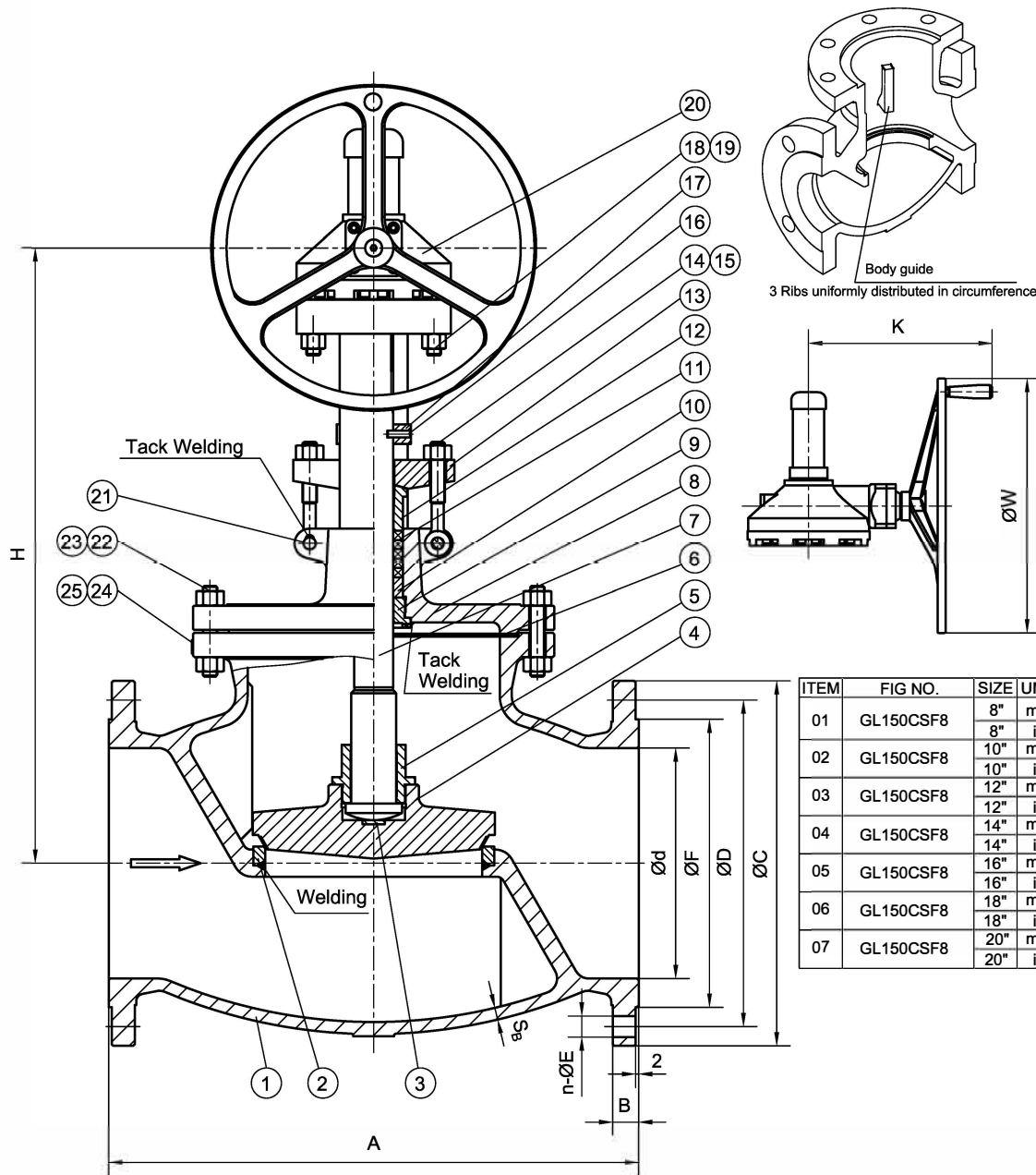

ITEM	NAME	MATERIAL
1	BODY	ASTM A216-WCB
2	SEAT	ASTM A105N+STL
3	DISC WASHER	ASTM A276-420
4	DISC	ASTM A105N+13%Cr
5	DISC BUSHING	ASTM A276-410
6	GASKET	304+GRAPHITE
7	STEM	ASTM A182-F6a
8	BONNET	ASTM A216-WCB
9	BACKSEAT	ASTM A276-420+STL
10	PACKING SPACER	ASTM A276-410
11	PACKING	INCONEL600+GRAPHITE
12	GLAND	ASTM A276-410
13	GLAND FLANGE	ASTM A216-WCB
14	EYE BOLT	ASTM A193-B7
15	NUT	ASTM A194-2H
16	ANTI-ROTATION PIN	AISI 1035
17	STEM GUIDE	AISI 1045
18	BOLT	ASTM A193-B7
19	NUT	ASTM A194-2H
20	GEAR	ASTM A216-WCB
21	PIN	AISI 1035
22	BOLT	ASTM A193-B7
23	NUT	ASTM A194-2H
24	NAMEPLATE	ASTM A240-304
25	RIVET	ASTM A240-304

NOTE:

1. API 622 LOW EMISSION PACKING

ITEM	FIG NO.	SIZE	UNIT	d	A	B	C	D	n	E	F	H	W	K	S <sub>b</sub>	Weight(lbs/kgs)
01	GL150CSF8	8"	mm	203	495	29	345	298.5	8	22	269.9	590	460	345	12.7	348/158
		8"	in	8.0	19.5	1.14	13.5	11.75	8	7/8	10.62	23.23	18.11	13.58	0.5	
02	GL150CSF8	10"	mm	254	622	30.6	405	362	12	25	323.8	658	610	420	14.2	608/276
		10"	in	10.0	24.5	1.2	16.0	14.25	12	1	12.75	25.9	24.02	16.54	0.56	
03	GL150CSF8	12"	mm	305	698	32.2	485	431.8	12	25	381	805	610	420	16	1069/485
		12"	in	12.0	27.5	1.27	19.0	17.00	12	1	15.00	31.7	24.02	16.54	0.63	
04	GL150CSF8	14"	mm	337	787	35.4	535	476.3	12	29	412.8	913	710	500	16.8	1213/550
		14"	in	13.27	31.0	1.39	21.0	18.75	12	1-1/8	16.25	35.94	27.95	19.69	0.66	
05	GL150CSF8	16"	mm	387	914	37	595	539.8	16	29	469.9	1007	710	500	17.5	1596/724
		16"	in	15.24	36.0	1.46	23.5	21.25	16	1-1/8	18.5	39.65	27.95	19.69	0.69	
06	GL150CSF8	18"	mm	438	978	40.1	635	577.9	16	32	533.4	1038	710	500	18.3	3086/1400
		18"	in	17.24	38.5	1.58	25	22.75	16	1-1/4	21.0	40.87	27.95	16.69	0.72	
07	GL150CSF8	20"	mm	489	978	43.3	700	635	20	32	584.2	1128	710	500	19.1	5732/2600
		20"	in	19.25	38.5	1.7	27.5	25.0	20	1-1/4	23.0	44.41	27.95	16.69	0.75	



**J.J. VALVE**  
Toll Free 800.582.5837 Local 310.605.0090

Here at J.J. Valve, we utilize a wide variety of products to meet your needs when it comes to Industrial valves.

TITLE: CAST STEEL GLOBE VALVE  
CLASS 150- API TRIM 8 -RF-GEAR OPERATED

MARKING SYSTEM	MSS-SP-25	INSPECTION & TEST:	API 598	MATERIAL:	ASTM A216 WCB	UNITS:	Inch, mm
DIM.OF FLANGE	ANSI B16.5	SHELL	HYDRO 450PSI	CLASS:	150	DATE:	4/15/19
FACE TO FACE	ANSI B16.10	SEAT	AIR N/A	SIZE:	8"-20"	SCALE:	N.T.S.
WALL THICKNESS	API 623	BACK SEAT	HYDRO 315PSI	DRAWN BY:	F.J.	FIG. No.:	<b>GL150CSF8-BG</b>
NO.	DATE	DESCRIPTION	PRPD	REVD	APP'D	DESIGNED	API 623, ANSI B16.34
CHK'D & APR'D BY: E.C.						REV: 1	DWG No.:

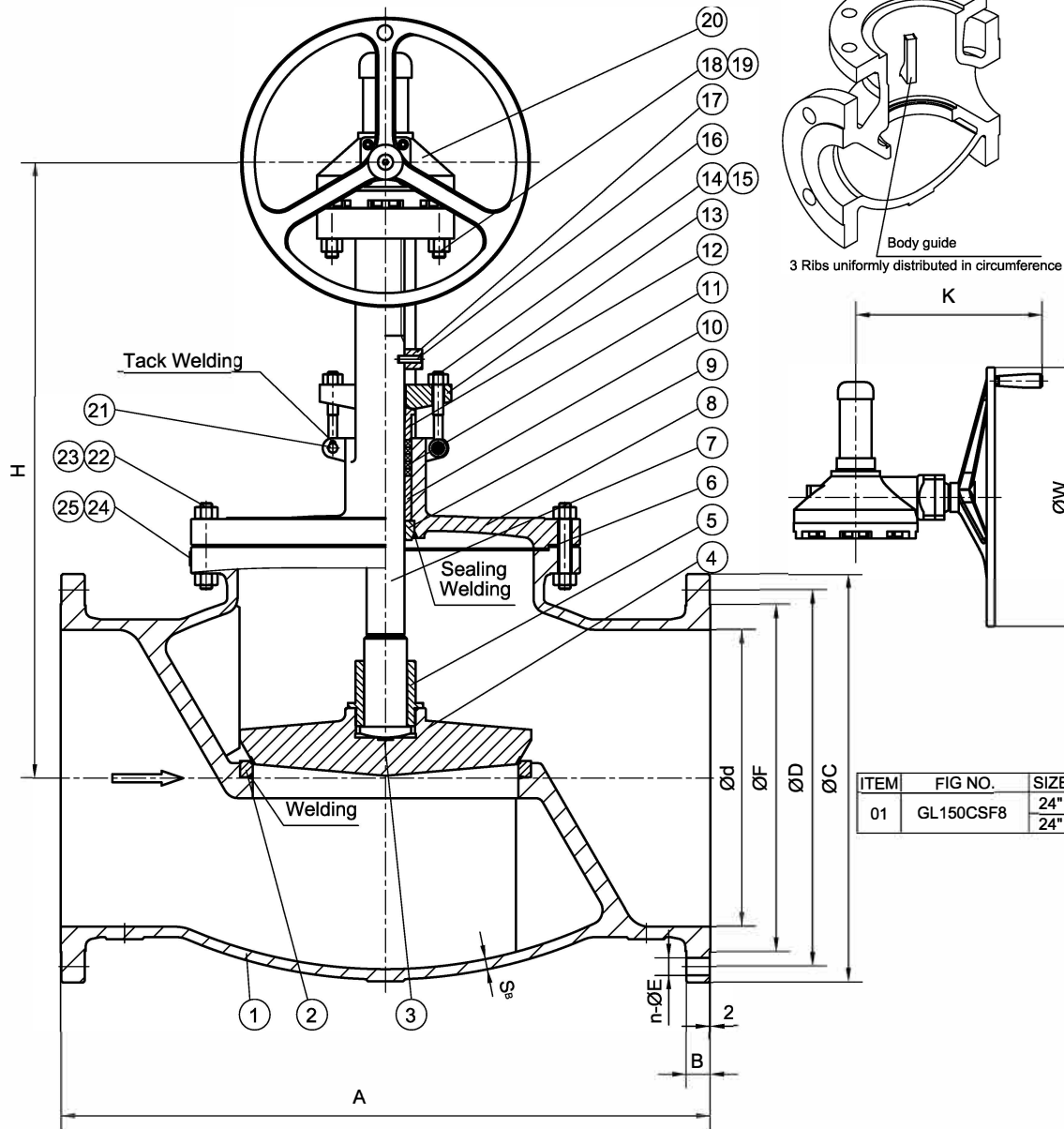

ITEM	NAME	MATERIAL
1	BODY	ASTM A216-WCB
2	SEAT	ASTM A105N+STL
3	DISC WASHER	ASTM A276-420
4	DISC	ASTM A105N+13%Cr
5	DISC BUSHING	ASTM A276-410
6	GASKET	304+GRAPHITE
7	STEM	ASTM A182-F6a
8	BONNET	ASTM A216-WCB
9	BACKSEAT	ASTM A276-420+STL
10	PACKING SPACER	ASTM A276-410
11	PACKING	INCONEL600+GRAPHITE
12	GLAND	ASTM A276-410
13	GLAND FLANGE	ASTM A216-WCB
14	EYE BOLT	ASTM A193-B7
15	NUT	ASTM A194-2H
16	ANTI-ROTATION PIN	AISI 1035
17	STEM GUIDE	AISI 1045
18	BOLT	ASTM A193-B7
19	NUT	ASTM A194-2H
20	GEAR	ASTM A216-WCB
21	PIN	AISI 1035
22	BOLT	ASTM A193-B7
23	NUT	ASTM A194-2H
24	NAMEPLATE	ASTM A240-304
25	RIVET	ASTM A240-304

NOTE:  
1. API 622 LOW EMISSION PACKING

ITEM	FIG NO.	SIZE	UNIT	d	A	B	C	D	n	E	F	H	W	K	S <sub>s</sub>	Weight(lbs/kgs)
01	GL150CSF8	24"	mm	591	1295	48.1	815	749.3	20	35	692.2	1300	800	605	20.6	8157/3700
		24"	in	23.27	51.0	1.89	32.0	29.5	20	1-3/8	27.25	51.18	31.5	23.82	0.81	



**J.J. VALVE**  
Toll Free 800.582.5837 Local 310.605.0090

Here at J.J. Valve, we utilize a wide variety of products to meet your needs when it comes to industrial valves.

TITLE: CAST STEEL GLOBE VALVE  
CLASS 150- API TRIM 8 -RF-GEAR OPERATED

MARKING SYSTEM	MSS-SP-25	INSPECTION & TEST:	API 598	MATERIAL:	ASTM A216 WCB	UNITS:	Inch, mm
DIM.OF FLANGE	ANSI B16.5	SHELL	HYDRO 450PSI	CLASS:	150	DATE:	4/15/19
FACE TO FACE	ANSI B16.10	SEAT	AIR N/A	SIZE:	24"	FIG. No.:	
WALL THICKNESS	API 623	BACK SEAT	HYDRO 315PSI	DRAWN BY:	F.J.	<b>GL150CSF8-BG</b>	
DESIGNED	API 623, ANSI B16.34	CHK'D & APR'D BY:	E.C.	REV:	1	DWG No.:	

NO.	DATE	DESCRIPTION	PRPD	REVD	APP'D
4/15/19	RELEASED		F.J.	E.C.	E.C.