

ITEM	NAME	MATERIAL
1	BODY	ASTM A216-WCB
2	SEAT	ASTM A105N+STL
3	DISC WASHER	ASTM A276-420
4	DISC	ASTM A105N+13%Cr
5	DISC COVER	ASTM A276-410
6	RTJ GASKET	AISI 1008
7	BONNET	ASTM A216-WCB
8	BACKSEAT	ASTM A276-420+STL
9	PACKING SPACER	ASTM A276-410
10	PACKING	INCONEL600+GRAPHITE
11	GLAND	ASTM A276-410
12	GLAND FLANGE	ASTM A216-WCB
13	EYE BOLT	ASTM A193-B7
14	NUT	ASTM A194-2H
15	STEM NUT	ASTM A439 D-2
16	HAMMER BLOCK	AISI 1045
17	COVER PLATE	AISI 1035
18	COUNTERSUNK BOLT	AISI 1035
19	NUT	ASTM A194-2H
20	WASHER	ASTM A283 GRC
21	HANDWHEEL	ASTM A536 60-40-18
22	SCREW	AISI 1025
23	STEM	ASTM A182-F6a
24	PIN	AISI 1035
25	BOLT	ASTM A193-B7
26	NUT	ASTM A194-2H
27	NAMEPLATE	ASTM A240-304
28	RIVET	ASTM A240-304

NOTE:

1. API 622 LOW EMISSION PACKING

ITEM	FIG NO.	SIZE	UNIT	d	A	B	C	D	n	E	F	H	W	S _s	Weight(lbs/kgs)
01	GL1500CSF8	2"	mm	48	368	38.1	215	165.1	8	25	92.1	435	350	19.1	271/123
		2"	in	1.89	14.5	1.5	8.5	6.5	8	1	3.62	17.13	13.78	0.75	
02	GL1500CSF8	3"	mm	70	470	47.7	265	203.2	8	32	127	590	500	23.9	474/215
		3"	in	2.76	18.5	1.88	10.5	8.0	8	1-1/4	5.0	23.23	19.7	0.94	
03	GL1500CSF8	4"	mm	92	546	54	310	241.3	8	35	157.2	670	560	28.7	869/394
		4"	in	3.62	21.5	2.13	12.25	9.5	8	1-3/8	6.19	26.38	22.0	1.13	



J.J. VALVE

Toll Free 800.582.5837 Local 310.605.0090

Here at J.J. Valve, we utilize a wide variety of products to meet your needs when it comes to industrial valves.

TITLE: CAST STEEL GLOBE VALVE
CLASS 1500- API TRIM 8- RF- HANDWHEEL OPERATED

MARKING SYSTEM	MSS-SP-25	INSPECTION & TEST: API 598	MATERIAL: ASTM A216 WCB	UNITS: Inch, mm
DIM.OF FLANGE	ANSI B16.5	SHELL HYDRO 5575PSI	CLASS: 1500	DATE: 09/25/18
FACE TO FACE	ANSI B16.10	SEAT AIR N/A	SI E: 2"-4"	SCALE: N.T.S.
WALL THICKNESS	API 623	BACK SEAT HYDRO 4080PSI	DRAWN BY: F.J.	FIG. No.: GL1500CSF8
NO. DATE DESCRIPTION PRP'D REV'D APP'D	DESIGNED	API 623, ANSI B16.34	CHK'D & APR'D BY: E.C.	REV: 1 DWG No.:

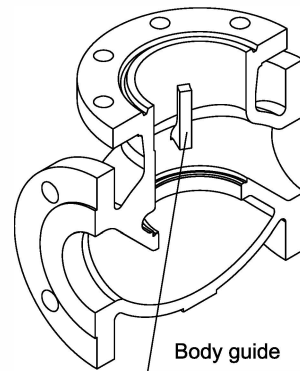
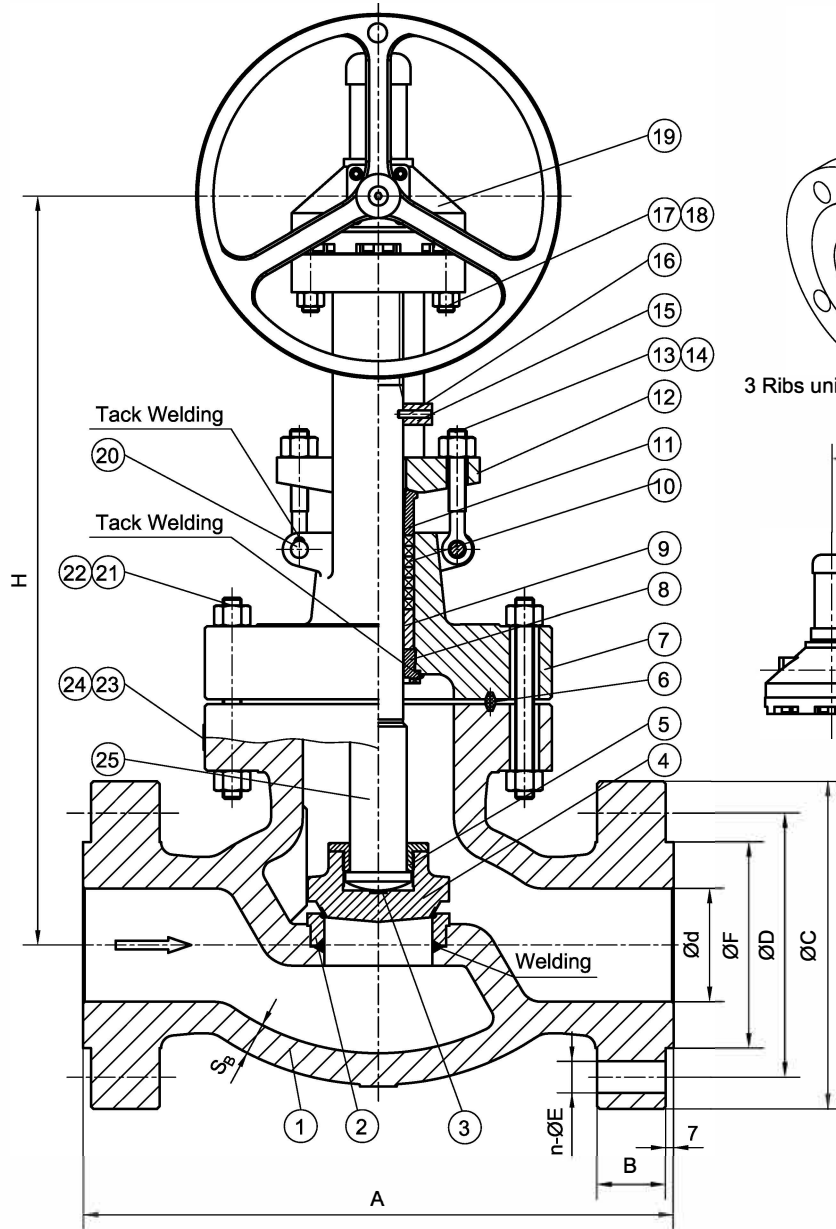

3 Ribs uniformly distributed in circumference

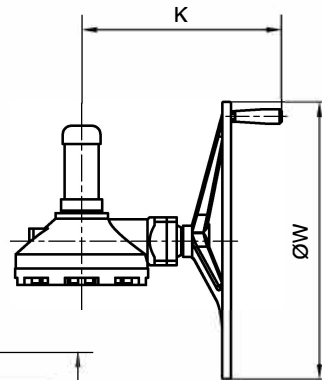

ITEM	NAME	MATERIAL
1	BODY	ASTM A216-WCB
2	SEAT	ASTM A105N+STL
3	DISC WASHER	ASTM A276-420
4	DISC	ASTM A105N+13%Cr
5	DISC BUSHING	ASTM A276-410
6	RTJ GASKET	AISI 1008
7	BONNET	ASTM A216-WCB
8	BACKSEAT	ASTM A276-420+STL
9	PACKING SPACER	ASTM A276-410
10	PACKING	INCONEL600+GRAPHITE
11	GLAND	ASTM A276-410
12	GLAND FLANGE	ASTM A216-WCB
13	EYE BOLT	ASTM A193-B7
14	NUT	ASTM A194-2H
15	STEM GUIDE	AISI 1045
16	ANTI-ROTATION PIN	AISI 1035
17	BOLT	ASTM A193-B7
18	NUT	ASTM A194-2H
19	GEAR	ASTM A216-WCB
20	PIN	AISI 1035
21	BOLT	ASTM A193-B7
22	NUT	ASTM A194-2H
23	NAMEPLATE	ASTM A240-304
24	RIVET	ASTM A240-304
25	STEM	ASTM A182-F6a

NOTE:

1. API 622 LOW EMISSION PACKING

ITEM	FIG NO.	SIZE	UNIT	d	A	B	C	D	n	E	F	H	W	K	S _s	Weight(lbs/kgs)
01	GL1500CSF8	6"	mm	136	705	82.6	395	317.5	12	38	215.9	910	710	580	38.1	1235/560
		6"	in	5.35	27.75	3.25	15.5	12.5	12	1-1/2	8.5	35.83	27.95	22.83	1.5	
02	GL1500CSF8	8"	mm	178	832	92.1	485	393.7	12	45	269.9	933	800	605	47.8	2183/990
		8"	in	7.0	32.75	3.62	19.0	15.5	12	1-3/4	10.62	36.73	31.5	23.82	1.88	

J.J. VALVE
Toll Free 800.582.5837 Local 310.605.0090
Here at J.J. Valve, we utilize a wide variety of products to meet your needs when it comes to industrial valves.

TITLE:				CAST STEEL GLOBE VALVE CLASS 1500- API TRIM 8 - RF - GEAR OPERATED			
MATERIAL: ASTM A216 WCB		UNITS: Inch, mm		CLASS: 1500		DATE: 09/25/18	
DIM.OF FLANGE: ANSI B16.5		SHELL: HYDRO		5575PSI		SCALE: N.T.S.	
FACE TO FACE: ANSI B16.10		SEAT: AIR		N/A		SIZE: 6" ø"	
WALL THICKNESS: API 623		BACK SEAT: HYDRO		4080PSI		DRAWN BY: F.J.	
NO. DATE: 4/4/19		DESCRIPTION: RELEASED		PRP'D: F.J.		E.C.: E.C.	
DESIGNED: API 623, ANSI B16.34		CHK'D & APR'D BY: E.C.		REV: 1		DWG No.: GL1500CSF8-GO	

NO.	DATE	DESCRIPTION	PRP'D	REV'D	APP'D	DESIGNED
4/4/19	RELEASED	F.J.	E.C.	E.C.		