

ITEM	NAME	MATERIAL
1	BODY	ASTM A216-WCB
2	SEAT	ASTM A105N+STL
3	SOLID WEDGE	ASTM A216-WCB+13%Cr
4	STEM	ASTM A182-F6a
5	BONNET	ASTM A216-WCB
6	RTJ GASKET	AISI 1008
7	BACKSEAT	ASTM A276-420
8	PACKING SPACER	ASTM A276-410
9	PACKING	INCONEL600+GRAPHITE
10	GLAND	ASTM A276-410
11	GLAND FLANGE	ASTM A216-WCB
12	EYE BOLT	ASTM A193-B7
13	NUT	ASTM A194-2H
14	GREASE FITTING	ASTM A283 GRC
15	HANDWHEEL	ASTM A536 60-40-18
16	HANDWHEEL NUT	AISI 1025
17	SCREW	AISI 1025
18	GLAND NUT	AISI 1025
19	STEM NUT	ASTM A439 D-2
20	BEARING	AISI 52100
21	PIN	AISI 1035
22	BOLT	ASTM A193-B7
23	NUT	ASTM A194-2H
24	NAMEPLATE	ASTM A240-304
25	RIVET	ASTM A240-304

NOTE:

1. FLEXIBLE WEDGE
2. API 624 QUALIFIED

ITEM	FIG NO.	SIZE	UNIT	d	A	B	C	D	n	E	F	H	W	S <sub>B</sub>	Weight(lbs/kgs)
01	GT1500CSF8	2"	mm	48	368	38.1	215	165.1	8	25	92.1	430	250	19.1	174/79
		2"	in	1.89	14.5	1.5	8.5	6.5	8	1	3.62	16.93	9.84	0.75	

						MARKING SYSTEM	MSS-SP-25	INSPECTION & TEST: API 598	MATERIAL: ASTM A216 WCB	UNITS: Inch, mm	
						DIM.OF FLANGE	ANSI B16.5	SHELL HYDRO 5575PSI	CLASS: 1500	DATE: 4/15/19	SCALE: N.T.S.
						FACE TO FACE	ANSI B16.10	SEAT AIR 80PSI	SIZE: 2"	FIG. No.:	
						WALL THICKNESS	API 600	BACK SEAT HYDRO 4080PSI	DRAWN BY: F.J.		<b>GT1500CSF8</b>
						DESIGNED	API 600, ANSI B16.34		CHK'D & APR'D BY: E.C.	REV: 1	DWG No.:

Toll Free 800.582.5837 Local 310.605.0090

Here at J.J. Valve, we utilize a wide variety of products to meet your needs when it comes to industrial valves.

TITLE: CAST STEEL GATE VALVE  
CLASS 1500- API TRIM 8 - RF - HANDWHEEL OPERATED



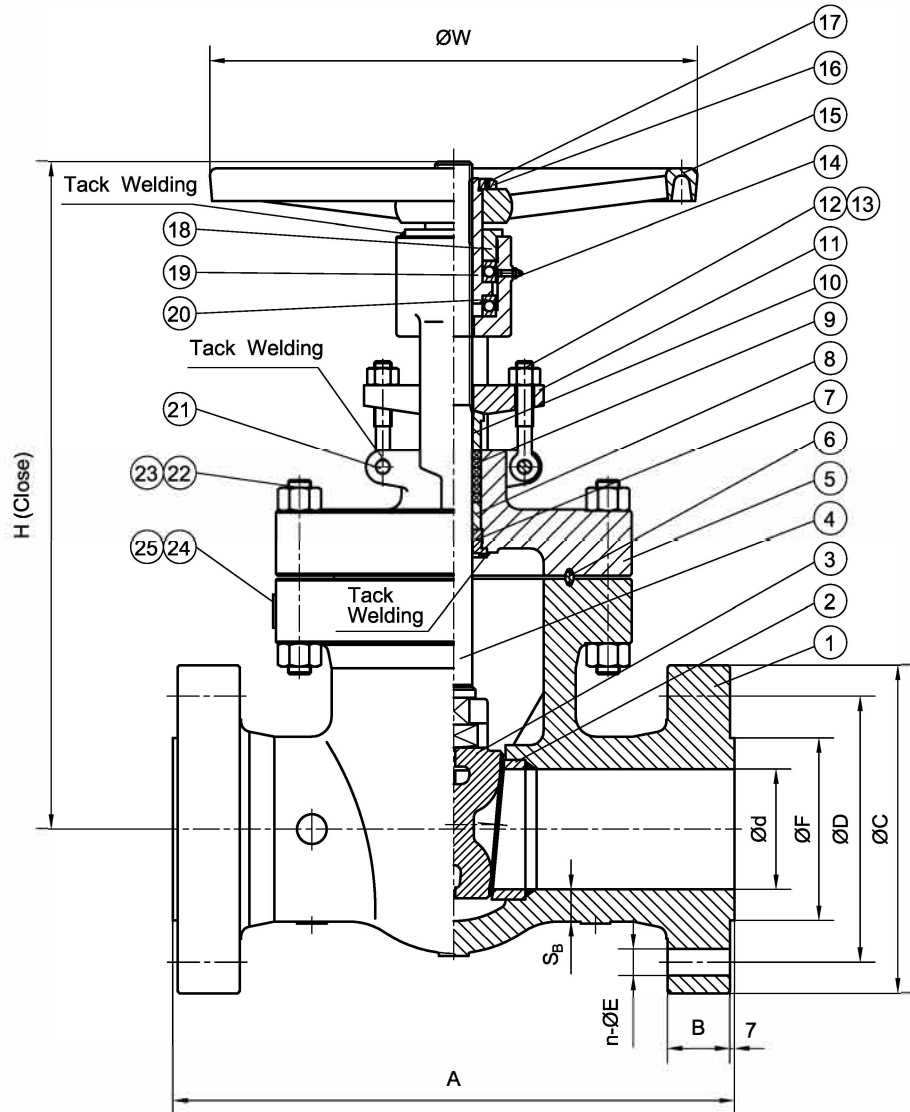

ITEM	NAME	MATERIAL
1	BODY	ASTM A216-WCB
2	SEAT	ASTM A105N+STL
3	FLEXIBLE WEDGE	ASTM A216-WCB+13%Cr
4	STEM	ASTM A182-F6a
5	BONNET	ASTM A216-WCB
6	RTJ GASKET	AISI 1008
7	BACKSEAT	ASTM A276-420
8	PACKING SPACER	ASTM A276-410
9	PACKING	INCONEL600+GRAPHITE
10	GLAND	ASTM A276-410
11	GLAND FLANGE	ASTM A216-WCB
12	EYE BOLT	ASTM A193-B7
13	NUT	ASTM A194-2H
14	GREASE FITTING	ASTM A283 GRC
15	HANDWHEEL	ASTM A536 60-40-18
16	HANDWHEEL NUT	AISI 1025
17	SCREW	AISI 1025
18	GLAND NUT	AISI 1025
19	STEM NUT	ASTM A439 D-2
20	BEARING	AISI 52100
21	PIN	AISI 1035
22	BOLT	ASTM A193-B7
23	NUT	ASTM A194-2H
24	NAMEPLATE	ASTM A240-304
25	RIVET	ASTM A240-304

NOTE:

1. FLEXIBLE WEDGE
2. API 624 QUALIFIED

ITEM	FIG NO.	SIZE	UNIT	d	A	B	C	D	n	E	F	H	W	S <sub>B</sub>	Weight(lbs/kgs)
01	GT1500CSF8	3"	mm	70	470	47.7	265	203.2	8	32	12.7	539	350	23.9	364/165
		3"	in	2.75	18.5	1.88	10.5	8.0	8	1-1/4	5.0	21.22	13.78	0.94	



**J.J. VALVE**  
Toll Free 800.582.5837 Local 310.605.0090

Here at J.J. Valve, we utilize a wide variety of products to meet your needs when it comes to industrial valves.

TITLE: CAST STEEL GATE VALVE  
CLASS 1500- API TRIM 8 - RF - HANDWHEEL OPERATED

MATERIAL: ASTM A216 WCB	UNITS: Inch, mm
CLASS: 1500 DATE: 4/15/19	SCALE: N.T.S.
SI E: 3"	FIG. No.:
<b>GT1500CSF8</b>	
DRAWN BY: F.J.	DWG No.:
CHK'D & APR'D BY: E.C.	REV: 1

NO.	DATE	DESCRIPTION	PRP'D	REV'D	APP'D	DESIGNED	MARKING SYSTEM	MSS-SP-25	INSPECTION & TEST: API 598	MATERIAL: ASTM A216 WCB	UNITS: Inch, mm
							DIM.OF FLANGE	ANSI B16.5	SHELL	HYDRO	5575PSI
							FACE TO FACE	ANSI B16.10	SEAT	AIR	80PSI
							WALL THICKNESS	API 600	BACK SEAT	HYDRO	4080PSI
							DESIGNED	API 600, ANSI B16.34			







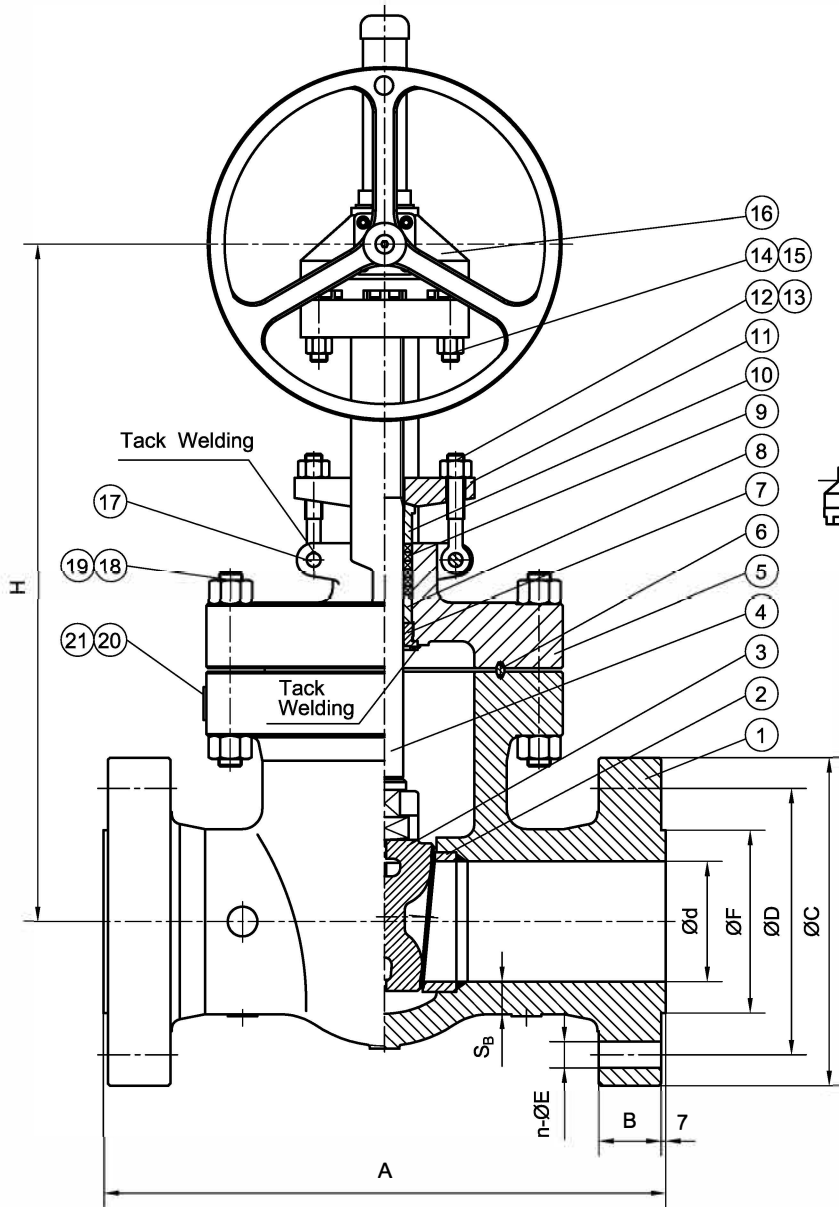

ITEM	NAME	MATERIAL
1	BODY	ASTM A216-WCB
2	SEAT	ASTM A105N+STL
3	FLEXIBLE WEDGE	ASTM A216-WCB+13%Cr
4	STEM	ASTM A182-F6a
5	BONNET	ASTM A216-WCB
6	RTJ GASKET	AISI 1008
7	BACKSEAT	ASTM A276-420
8	PACKING SPACER	ASTM A276-410
9	PACKING	INCONEL600+GRAPHITE
10	GLAND	ASTM A276-410
11	GLAND FLANGE	ASTM A216-WCB
12	EYE BOLT	ASTM A193-B7
13	NUT	ASTM A194-2H
14	BOLT	ASTM A193-B7
15	NUT	ASTM A194-2H
16	GEAR	ASTM A216-WCB
17	PIN	AISI 1035
18	BOLT	ASTM A193-B7
19	NUT	ASTM A194-2H
20	NAMEPLATE	ASTM A240-304
21	RIVET	ASTM A240-304

NOTE:

1. FLEXIBLE WEDGE
2. API 624 QUALIFIED

ITEM	FIG NO.	SIZE	UNIT	d	A	B	C	D	n	E	F	H	W	K	S <sub>b</sub>	Weight(lbs/kgs)
01	GT1500CSF8	3"	mm	70	470	47.7	265	203.2	8	32	127	510	310	310	23.9	364/165
		3"	in	2.75	18.5	1.88	10.5	8.0	8	1-1/4	5.0	20.1	12.2	12.2	0.94	



**J.J. VALVE**

Toll Free 800.582.5837 Local 310.605.0090

Here at J.J. Valve, we utilize a wide variety of products to meet your needs when it comes to industrial valves.

TITLE: CAST STEEL GATE VALVE  
CLASS 1500- API TRIM 8 - RF - GEAR OPERATED

MATERIAL: ASTM A216 WCB	UNITS: Inch, mm
CLASS: 1500 DATE: 4/15/19	SCALE: N.T.S.
SIZE: 3"	FIG. No.: GT1500CSF8GO
DRAWN BY: F.J.	
CHK'D & APR'D BY: E.C.	REV: 1 DWG No.:

						MARKING SYSTEM	MSS-SP-25	INSPECTION & TEST: API 598	MATERIAL: ASTM A216 WCB
						DIM.OF FLANGE	ANSI B16.5	SHELL HYDRO 5575PSI	CLASS: 1500 DATE: 4/15/19
						FACE TO FACE	ANSI B16.10	SEAT AIR 80PSI	SIZE: 3" FIG. No.:
						WALL THICKNESS	API 600	BACK SEAT HYDRO 4080PSI	DRAWN BY: F.J.
						DESIGNED	API 600, ANSI B16.34		CHK'D & APR'D BY: E.C. REV: 1 DWG No.:

4/15/19	RELEASED	F.J.	E.C.	E.C.	
NO.	DATE	DESCRIPTION	PRPD	REV'D	APP'D

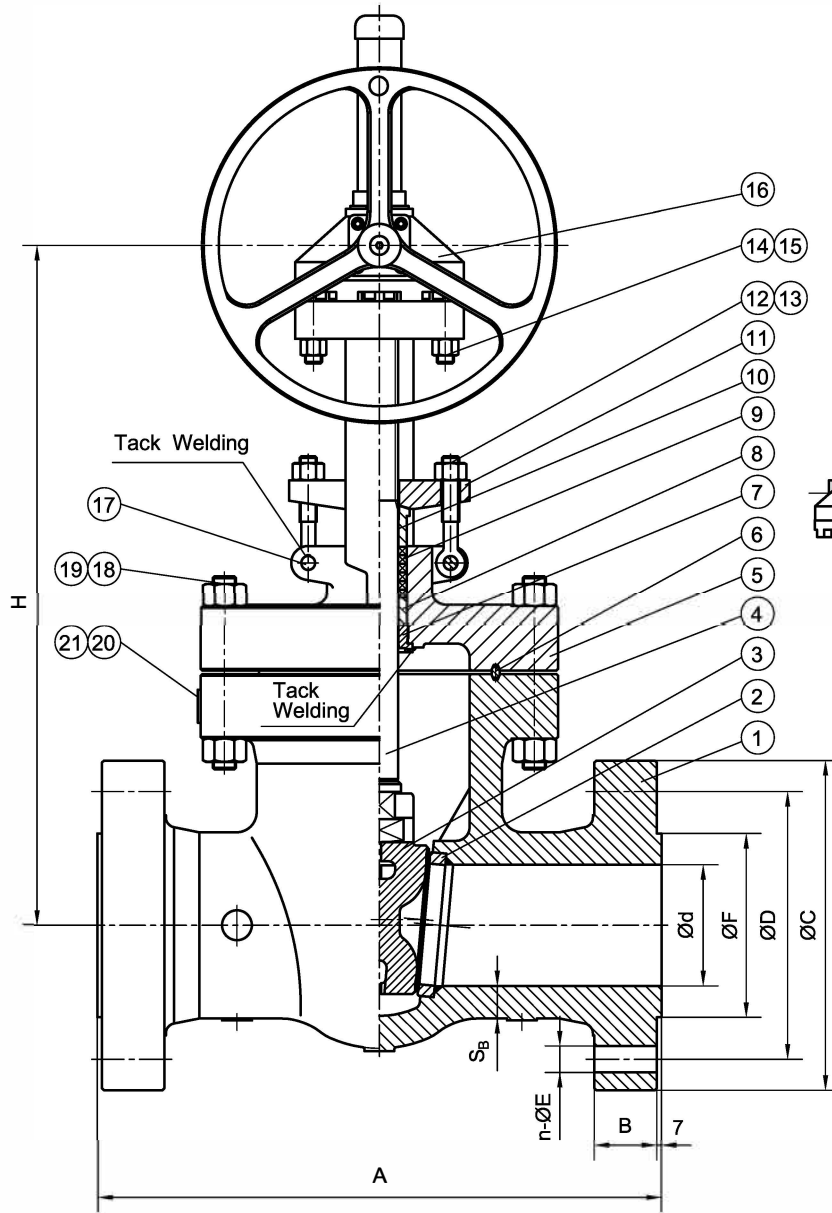

ITEM	NAME	MATERIAL
1	BODY	ASTM A216-WCB
2	SEAT	ASTM A105N+STL
3	FLEXIBLE WEDGE	ASTM A216-WCB+13%Cr
4	STEM	ASTM A182-F6a
5	BONNET	ASTM A216-WCB
6	RTJ GASKET	AISI 1008
7	BACKSEAT	ASTM A276-420
8	PACKING SPACER	ASTM A276-410
9	PACKING	INCONEL600+GRAPHITE
10	GLAND	ASTM A276-410
11	GLAND FLANGE	ASTM A216-WCB
12	EYE BOLT	ASTM A193-B7
13	NUT	ASTM A194-2H
14	BOLT	ASTM A193-B7
15	NUT	ASTM A194-2H
16	GEAR	ASTM A216-WCB
17	PIN	AISI 1035
18	BOLT	ASTM A193-B7
19	NUT	ASTM A194-2H
20	NAMEPLATE	ASTM A240-304
21	RIVET	ASTM A240-304

NOTE:

- 1. FLEXIBLE WEDGE
- 2. API 624 QUALIFIED

ITEM	FIG NO.	SIZE	UNIT	d	A	B	C	D	n	E	F	H	W	K	S <sub>b</sub>	Weight(lbs/kgs)
01	GT1500CSF8	4"	mm	92	546	54	310	241.3	8	35	157.2	621	310	310	28.7	547/248
		4"	in	3.62	21.5	2.13	12.25	9.5	8	1-3/8	6.19	24.45	12.2	12.2	1.13	
02	GT1500CSF8	6"	mm	136	705	82.6	395	317.5	12	38	215.9	820	610	420	38.1	1124/510
		6"	in	5.35	27.75	3.25	15.5	12.5	12	1-1/2	8.5	32.28	24.0	16.53	1.5	



**J.J. VALVE**

Toll Free 800.582.5837 Local 310.605.0090

Here at J.J. Valve, we utilize a wide variety of products to meet your needs when it comes to industrial valves.

TITLE:		CAST STEEL GATE VALVE	
		CLASS 1500- API TRIM 8 - RF - GEAR OPERATED	
MATERIAL:	ASTM A216 WCB	UNITS:	Inch, mm
CLASS:	1500	DATE:	4/15/19
SCALE:	N.T.S.	FIG. No.:	
SIZE:	4"-6"	FIG. No.:	<b>GT1500CSF8 GO</b>
DRAWN BY:	F.J.		
CHK'D & APR'D BY:	E.C.	REV:	1
DWG No.:			

NO.	DATE	DESCRIPTION	PRP'D	REV'D	APP'D	DESIGNED	MARKING SYSTEM	MSS-SP-25	INSPECTION & TEST: API 598	WALL THICKNESS	FACE TO FACE	DIM.OF FLANGE
	4/15/19	RELEASED	F.J.	E.C.	E.C.					API 600	SEAT	ANSI B16.5
										API 600	AIR	ANSI B16.10
										API 600, ANSI B16.34	HYDRO	

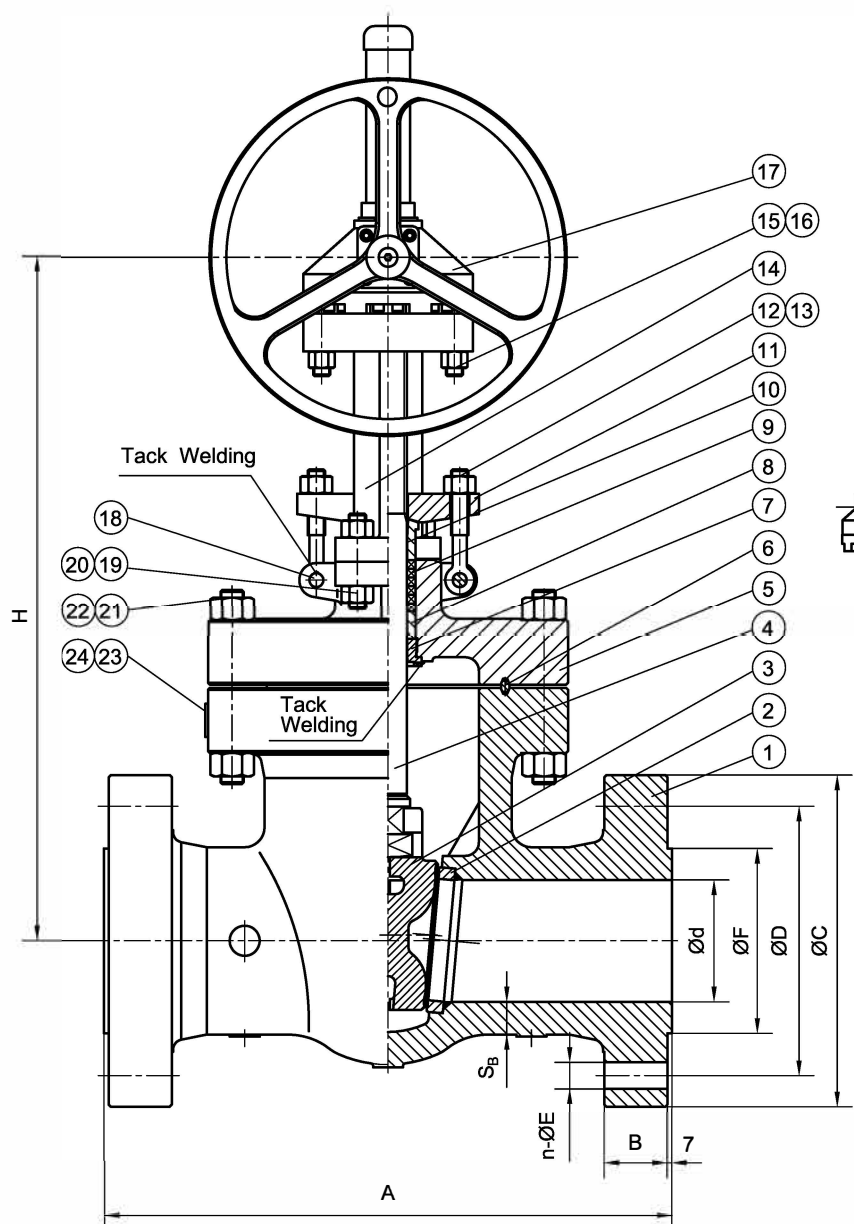

ITEM	NAME	MATERIAL
1	BODY	ASTM A216-WCB
2	SEAT	ASTM A105N+STL
3	FLEXIBLE WEDGE	ASTM A216-WCB+13%Cr
4	STEM	ASTM A182-F6a
5	BONNET	ASTM A216-WCB
6	RTJ GASKET	AISI 1008
7	BACKSEAT	ASTM A276-420
8	PACKING SPACER	ASTM A276-410
9	PACKING	INCONEL600+GRAPHITE
10	GLAND	ASTM A276-410
11	GLAND FLANGE	ASTM A216-WCB
12	EYE BOLT	ASTM A193-B7
13	NUT	ASTM A194-2H
14	YOKE	ASTM A216-WCB
15	BOLT	ASTM A193-B7
16	NUT	ASTM A194-2H
17	GEAR	ASTM A216-WCB
18	PIN	AISI 1035
19	BOLT	ASTM A193-B7
20	NUT	ASTM A194-2H
21	BOLT	ASTM A193-B7
22	NUT	ASTM A194-2H
23	NAMEPLATE	ASTM A240-304
24	RIVET	ASTM A240-304

NOTE:  
 1. FLEXIBLE WEDGE  
 2. API 624 QUALIFIED

ITEM	FIG NO.	SIZE	UNIT	d	A	B	C	D	n	E	F	H	W	K	S <sub>B</sub>	Weight(lbs/kgs)
01	GT1500CSF8	8"	mm	178	832	92.1	485	393.7	12	45	269.9	917	610	420	47.8	2293/1040
		8"	in	7.0	32.75	3.62	19.0	15.5	12	1-3/4	10.62	36.1	24.0	16.53	1.88	
02	GT1500CSF8	10"	mm	222	991	108	585	482.6	12	51	323.8	1075	710	500	57.1	4211/1910
		10"	in	8.74	39.0	4.25	23.0	19.0	12	2	12.75	42.32	27.95	19.69	2.25	

					MARKING SYSTEM	MSS-SP-25	INSPECTION & TEST: API 598			MATERIAL: ASTM A216 WCB			UNITS: Inch, mm		
					DIM.OF FLANGE	ANSI B16.5	SHELL	HYDRO	5575PSI	CLASS: 1500			DATE: 4/15/19		SCALE: N.T.S.
					FACE TO FACE	ANSI B16.10	SEAT	AIR	80PSI	SIZE: 8"-10"			FIG. No.: GT1500CSF8GO		
					WALL THICKNESS	API 600	BACK SEAT	HYDRO	4080PSI	DRAWN BY: F.J.					
△	4/15/19	RELEASED	F.J.	E.C.	E.C.	DESIGNED			API 600, ANSI B16.34			CHK'D & APR'D BY: E.C.	REV: 1	DWG No.:	

**J.J. VALVE**  
 Toll Free 800.582.5837 Local 310.605.0090  
 Here at J.J. Valves, we utilize a wide variety of products to meet your needs when it comes to industrial valves.

TITLE: CAST STEEL GATE VALVE  
 CLASS 1500- API TRIM 8 - RF - GEAR OPERATED



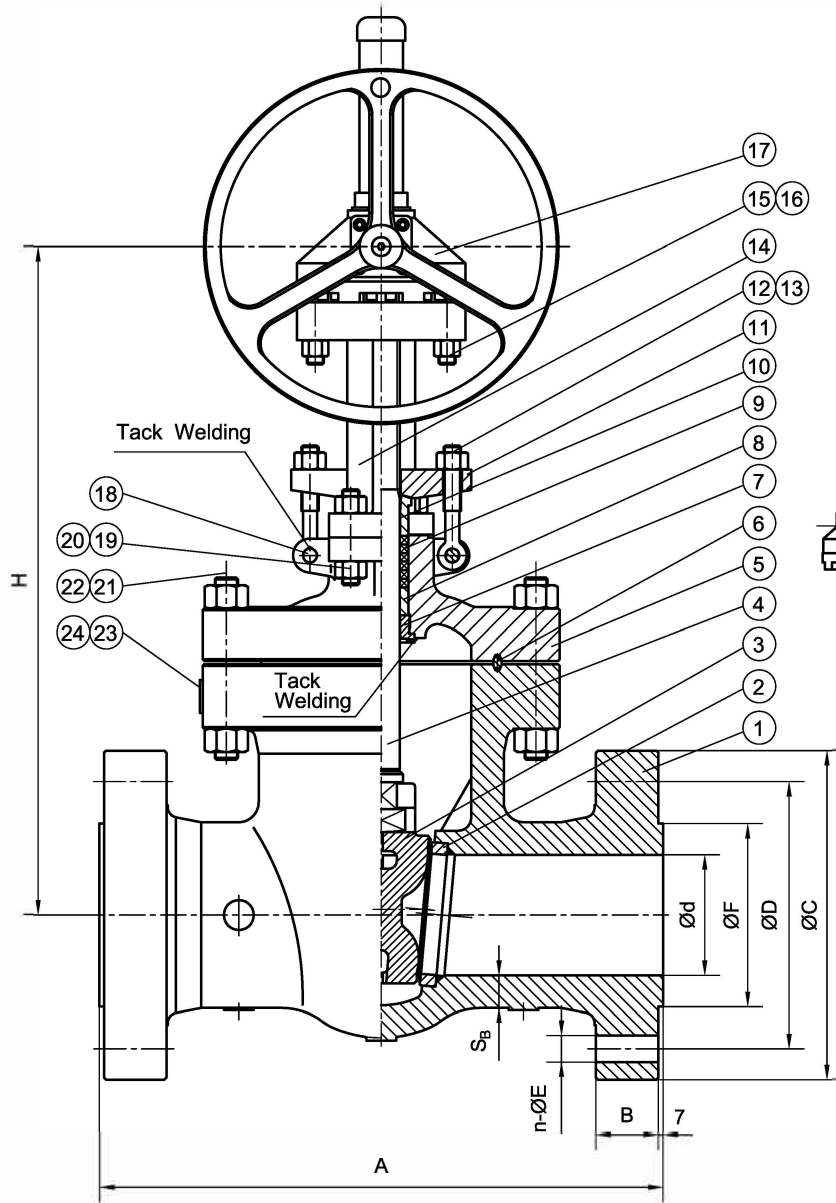

ITEM	NAME	MATERIAL
1	BODY	ASTM A216-WCB
2	SEAT	ASTM A105N+STL
3	FLEXIBLE WEDGE	ASTM A216-WCB+13%Cr
4	STEM	ASTM A182-F6a
5	BONNET	ASTM A216-WCB
6	RTJ GASKET	AISI 1008
7	BACKSEAT	ASTM A276-420
8	PACKING SPACER	ASTM A276-410
9	PACKING	INCONEL600+GRAPHITE
10	GLAND	ASTM A276-410
11	GLAND FLANGE	ASTM A216-WCB
12	EYE BOLT	ASTM A193-B7
13	NUT	ASTM A194-2H
14	YOKE	ASTM A216-WCB
15	BOLT	ASTM A193-B7
16	NUT	ASTM A194-2H
17	GEAR	ASTM A216-WCB
18	PIN	AISI 1035
19	BOLT	ASTM A193-B7
20	NUT	ASTM A194-2H
21	BOLT	ASTM A193-B7
22	NUT	ASTM A194-2H
23	NAMEPLATE	ASTM A240-304
24	RIVET	ASTM A240-304

NOTE:

- 1. FLEXIBLE WEDGE
- 2. API 624 QUALIFIED

ITEM	FIG NO.	SIZE	UNIT	d	A	B	C	D	n	E	F	H	W	K	S <sub>B</sub>	Weight(lbs/kgs)
01	GT1500CSF8	12"	mm	263	1130	123.9	675	571.5	16	54	381	1165	710	500	66.8	5919/2685
		12"	in	10.35	44.5	4.88	26.5	22.5	16	2-1/8	15.0	45.87	27.95	19.69	2.63	

				MARKING SYSTEM	MSS-SP-25	INSPECTION & TEST: API 598			MATERIAL: ASTM A216 WCB			UNITS: Inch, mm				
				DIM.OF FLANGE	ANSI B16.5	SHELL	HYDRO	5575PSI	CLASS: 1500	DATE: 4/15/19	SCALE: N.T.S.					
				FACE TO FACE	ANSI B16.10	SEAT	AIR	80PSI	SIZE: 12"	FIG. No.: GT1500CSF8GO						
				WALL THICKNESS	API 600	BACK SEAT	HYDRO	4080PSI	DRAWN BY: F.J.							
				NO.	DATE	DESCRIPTION	PRPD	REV'D	APP'D	DESIGNED	API 600, ANSI B16.34		CHK'D & APR'D BY: E.C.	REV: 1	DWG No.:	

Toll Free 800.582.5837 Local 310.605.0090

Here at J.J. Valve, we utilize a wide variety of products to meet your needs when it comes to industrial valves.

TITLE: CAST STEEL GATE VALVE  
CLASS 1500- API TRIM 8 - RF - GEAR OPERATED