

ITEM	NAME	MATERIAL
1	BODY	ASTM A216-WCB
2	SEAT	ASTM A105N+STL
3	DISC WASHER	ASTM A276-420
4	DISC	ASTM A105N+13%Cr
5	DISC BUSHING	ASTM A276-410
6	GASKET	304+GRAPHITE
7	STEM	ASTM A182-F6a
8	BONNET	ASTM A216-WCB
9	BACKSEAT	ASTM A276-420+STL
10	PACKING SPACER	ASTM A276-410
11	PACKING	INCONEL600+GRAPHITE
12	GLAND	ASTM A276-410
13	GLAND FLANGE	ASTM A216-WCB
14	EYE BOLT	ASTM A193-B7
15	NUT	ASTM A194-2H
16	STEM NUT	ASTM A439 D-2
17	SCREW	AISI 1025
18	WASHER	ASTM A283 GRC
19	NUT	ASTM A194-2H
20	HANDWHEEL	ASTM A536 60-40-18
21	PIN	AISI 1035
22	BOLT	ASTM A193-B7
23	NUT	ASTM A194-2H
24	NAMEPLATE	ASTM A240-304
25	RIVET	ASTM A240-304

NOTE:
1. API 622 LOW EMISSION PACKING

ITEM	FIG NO.	SIZE	UNIT	d	A	B	C	D	n	E	F	H	W	S _b	Weight(lbs/kgs)
01	GL300CSF8	2"	mm	51	267	22.7	165	127	8	19	92.1	319	200	9.7	68/31
		2"	in	2.0	10.5	0.89	6.5	5.0	8	3/4	3.62	12.56	7.87	0.38	
02	GL300CSF8	2-1/2"	mm	64	292	26	190	149.2	8	22	104.8	383	250	11.2	84/38
		2-1/2"	in	2.5	11.5	1.02	7.5	5.88	8	7/8	4.12	15.08	9.84	0.44	
03	GL300CSF8	3"	mm	76	318	29	210	168.3	8	22	127	408	250	11.9	112/51
		3"	in	3.0	12.5	1.14	8.25	6.62	8	7/8	5.0	16.06	9.84	0.47	
04	GL300CSF8	4"	mm	102	356	32.2	255	200	8	22	157.2	497	350	12.7	168/76
		4"	in	4.0	14.0	1.27	10.0	7.88	8	7/8	6.19	19.57	11.81	0.5	

				MARKING SYSTEM	MSS-SP-25	INSPECTION & TEST: API 598			MATERIAL: ASTM A216 WCB			UNITS: Inch, mm		
				DIM.OF FLANGE	ANSI B16.5	SHELL	HYDRO	1125PSI	CLASS: 300	DATE: 4/15/19	SCALE: N.T.S.			
				FACE TO FACE	ANSI B16.10	SEAT	AIR	N/A	SIZE: 2"-4"	FIG. No.: GL300CSF8				
				WALL THICKNESS	API 623	BACK SEAT	HYDRO	815PSI	DRAWN BY: F.J.					
NO.	DATE	DESCRIPTION	PRP'D	REV'D	APP'D	DESIGNED	API 623, ANSI B16.34			CHKD & APR'D BY: E.C.	REV: 1	DWG.No.:		

Toll Free 800.582.5837 Local 310.605.0090

Here at J.J. Valve, we utilize a wide variety of products to meet your needs when it comes to industrial valves.

TITLE: CAST STEEL GLOBE VALVE
CLASS 300- API TRIM 8 -RF- HANDWHEEL OPERATED

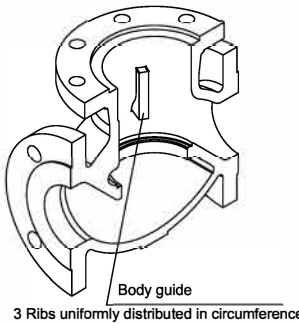
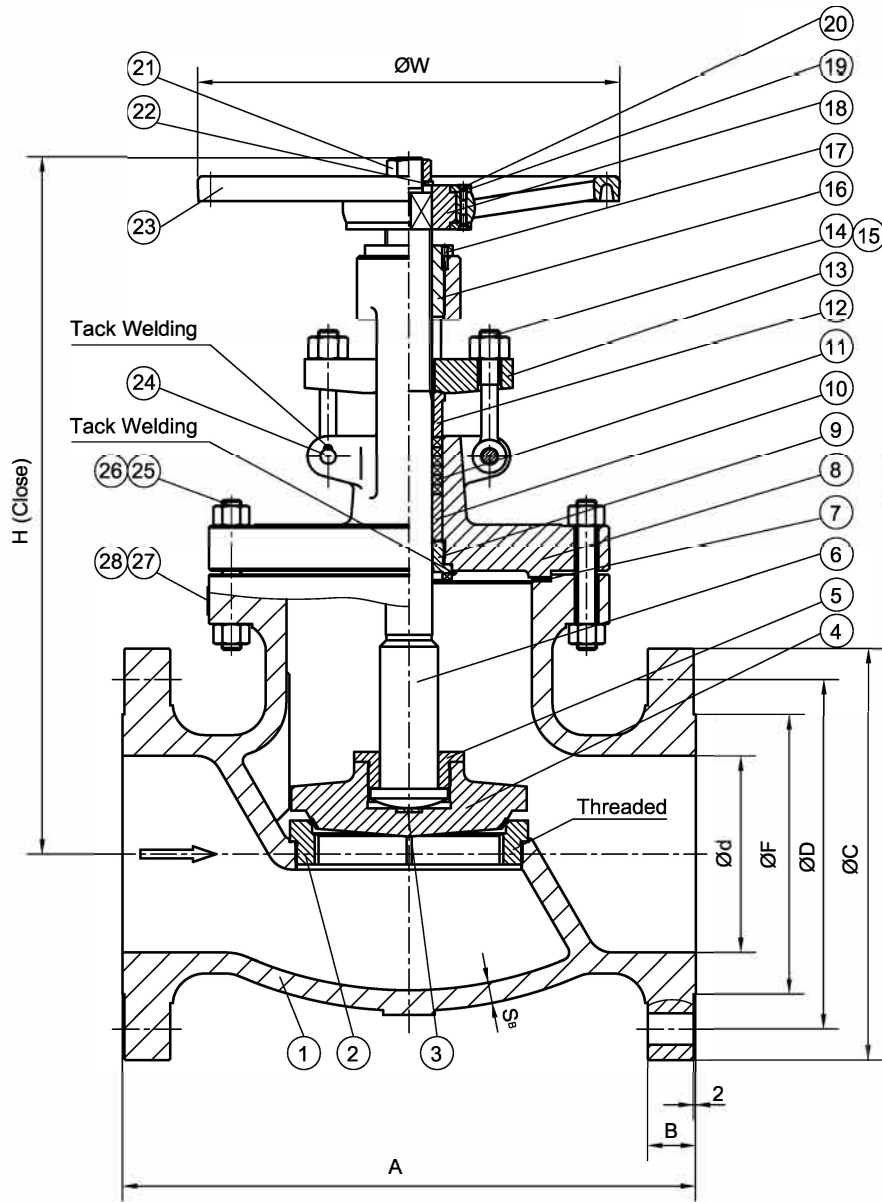

ITEM	NAME	MATERIAL
1	BODY	ASTM A216-WCB
2	SEAT	ASTM A105N+STL
3	DISC WASHER	ASTM A276-420
4	DISC	ASTM A105N+13%Cr
5	DISC BUSHING	ASTM A276-410
6	GASKET	304+GRAPHITE
7	STEM	ASTM A182-F6a
8	BONNET	ASTM A216-WCB
9	BACKSEAT	ASTM A276-420+STL
10	PACKING SPACER	ASTM A276-410
11	PACKING	INCONEL600+GRAPHITE
12	GLAND	ASTM A276-410
13	GLAND FLANGE	ASTM A216-WCB
14	EYE BOLT	ASTM A193-B7
15	NUT	ASTM A194-2H
16	STEM NUT	ASTM A439 D-2
17	SCREW	AISI 1025
18	HAMMER BLOCK	AISI 1045
19	COVER PLATE	AISI 1035
20	COUNTERSUNK BOLT	AISI 1035
21	NUT	ASTM A194-2H
22	WASHER	ASTM A283 GRC
23	HANDWHEEL	ASTM A536 60-40-18
24	PIN	AISI 1035
25	BOLT	ASTM A193-B7
26	NUT	ASTM A194-2H
27	NAMEPLATE	ASTM A240-304
28	RIVET	ASTM A240-304

NOTE:
1. API 622 LOW EMISSION PACKING

ITEM	FIG NO.	SIZE	UNIT	d	A	B	C	D	n	E	F	H	W	S _b	Weight(lbs/kgs)
01	GL300CSF8	6"	mm	152	444	37	320	26.99	12	22	215.9	576	450	16	340/154
		6"	in	6.0	17.5	1.46	12.5	10.62	12	7/8	8.5	22.68	17.72	0.63	



J.J. VALVE
Toll Free 800.582.5837 Local 310.605.0090

Here at J.J. Valve, we utilize a wide variety of products to meet your needs when it comes to industrial valves.

TITLE: CAST STEEL GLOBE VALVE
CLASS 300- API TRIM 8 -RF- HANDWHEEL OPERATED

MARKING SYSTEM	MSS-SP-25	INSPECTION & TEST:	API 598	MATERIAL:	ASTM A216 WCB	UNITS:	Inch, mm
DIM.OF FLANGE	ANSI B16.5	SHELL	HYDRO 1125PSI	CLASS:	300	DATE:	4/15/19
FACE TO FACE	ANSI B16.10	SEAT	AIR N/A	SI Z:	6"	SCALE:	N.T.S.
WALL THICKNESS	API 623	BACK SEAT	HYDRO 815PSI	DRAWN BY:	F.J.	GL300CSF8	
NO.	DATE	DESCRIPTION	PRPD	REV'D	APP'D	CHK'D & APR'D BY:	E.C. REV: 1 DWG No.:

4/15/19	RELEASED	F.J.	E.C.	E.C.	
NO.	DATE	DESCRIPTION	PRPD	REV'D	APP'D

MARKING SYSTEM	MSS-SP-25	INSPECTION & TEST:	API 598		
DIM.OF FLANGE	ANSI B16.5	SHELL	HYDRO 1125PSI		
FACE TO FACE	ANSI B16.10	SEAT	AIR N/A		
WALL THICKNESS	API 623	BACK SEAT	HYDRO 815PSI		
NO.	DATE	DESCRIPTION	PRPD	REV'D	APP'D

MATERIAL:	ASTM A216 WCB	UNITS:	Inch, mm
CLASS:	300	DATE:	4/15/19
SI Z:	6"	SCALE:	N.T.S.
DRAWN BY:	F.J.	GL300CSF8	
CHK'D & APR'D BY:	E.C.	REV:	1 DWG No.:

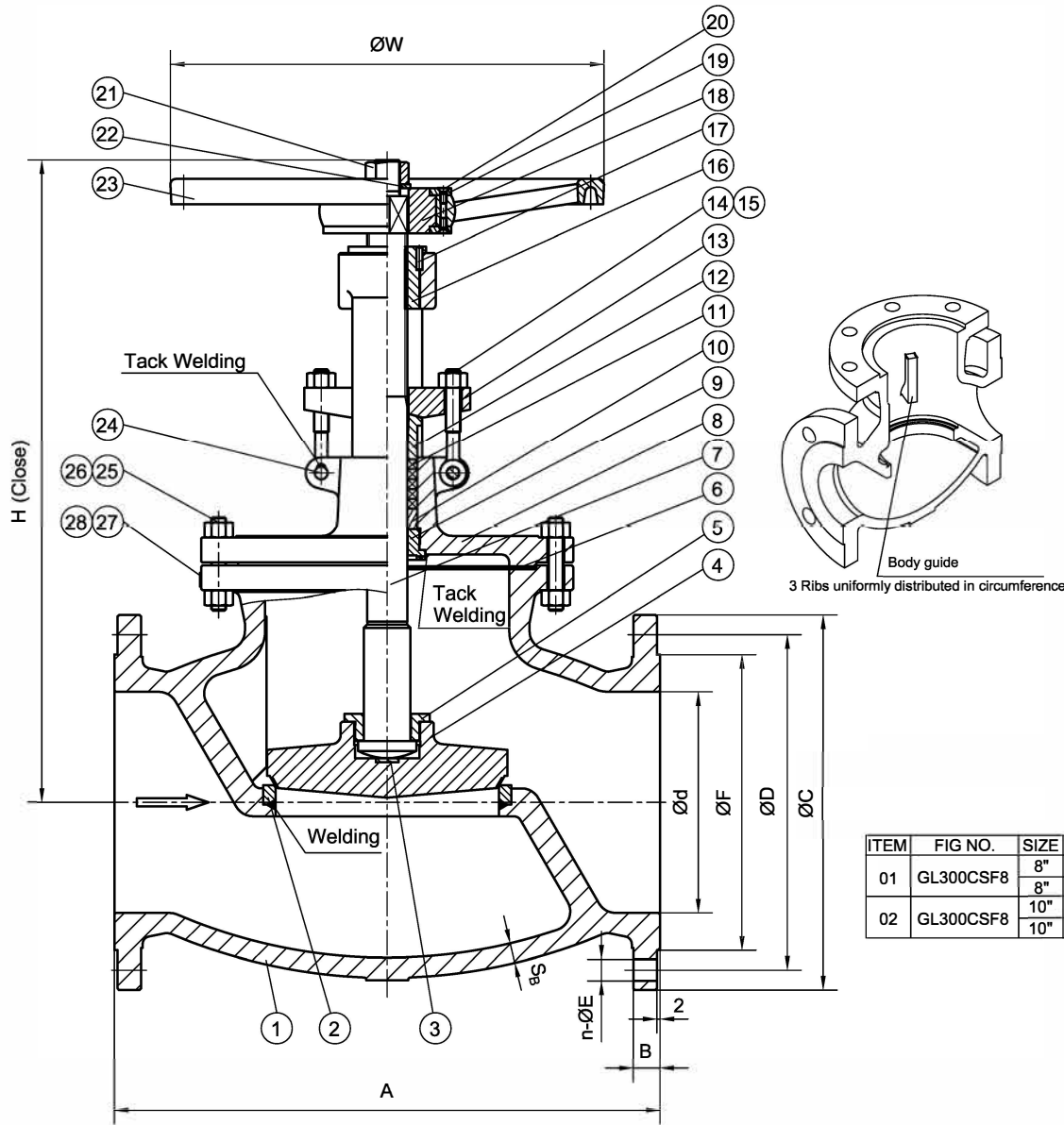

ITEM	NAME	MATERIAL
1	BODY	ASTM A216-WCB
2	SEAT	ASTM A105N+STL
3	DISC WASHER	ASTM A276-420
4	DISC	ASTM A105N+13%Cr
5	DISC BUSHING	ASTM A276-410
6	GASKET	304+GRAPHITE
7	STEM	ASTM A182-F6a
8	BONNET	ASTM A216-WCB
9	BACKSEAT	ASTM A276-420+STL
10	PACKING SPACER	ASTM A276-410
11	PACKING	INCONEL600+GRAPHITE
12	GLAND	ASTM A276-410
13	GLAND FLANGE	ASTM A216-WCB
14	EYE BOLT	ASTM A193-B7
15	NUT	ASTM A194-2H
16	STEM NUT	ASTM A439 D-2
17	SCREW	AISI 1025
18	HAMMER BLOCK	AISI 1045
19	COVER PLATE	AISI 1035
20	COUNTERSUNK BOLT	AISI 1035
21	NUT	ASTM A194-2H
22	WASHER	ASTM A283 GRC
23	HANDWHEEL	ASTM A536 60-40-18
24	PIN	AISI 1035
25	BOLT	ASTM A193-B7
26	NUT	ASTM A194-2H
27	NAMEPLATE	ASTM A240-304
28	RIVET	ASTM A240-304

NOTE:
1. API 622 LOW EMISSION PACKING

ITEM	FIG NO.	SIZE	UNIT	d	A	B	C	D	n	E	F	H	W	S _s	Weight(lbs/kgs)
01	GL300CSF8	8"	mm	203	559	41.7	380	330.2	12	25	269.9	808	560	17.5	655/297
		8"	in	8.0	22.0	1.64	15.0	13.0	12	1	10.62	31.81	22.05	0.69	
02	GL300CSF8	10"	mm	254	622	48.1	445	387.4	16	29	323.8	817	560	19.1	1003/455
		10"	in	10.0	24.5	1.89	17.5	15.25	16	1-1/8	12.75	32.16	22.05	0.75	

				MARKING SYSTEM	MSS-SP-25	INSPECTION & TEST: API 598			MATERIAL: ASTM A216 WCB			UNITS: Inch, mm		
				DIM.OF FLANGE	ANSI B16.5	SHELL	HYDRO	1125PSI	CLASS: 300	DATE: 4/15/19	SCALE: N.T.S.			
				FACE TO FACE	ANSI B16.10	SEAT	AIR	N/A	SIZE: 8"-12"	FIG. No.: GL300CSF8				
				WALL THICKNESS	API 623	BACK SEAT	HYDRO	815PSI	DRAWN BY: F.J.					
NO.	DATE	DESCRIPTION	PRPD	REV'D	APP'D	DESIGNED	API 623, ANSI B16.34		CHK'D & APR'D BY: E.C.		REV: 1	DWG No.:		



J.J. VALVE

Toll Free **800.582.5837** Local **310.805.0090**

Here at J.J. Valve, we utilize a wide variety of products to meet your needs when it comes to industrial valves.

TITLE: **CAST STEEL GLOBE VALVE**
CLASS 300- API TRIM 8- RF- HANDWHEEL OPERATED

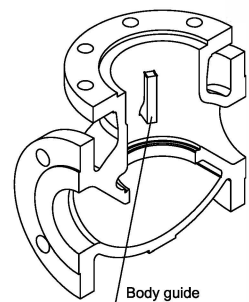
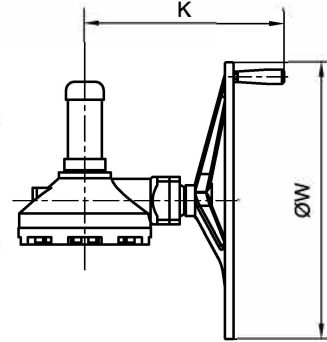
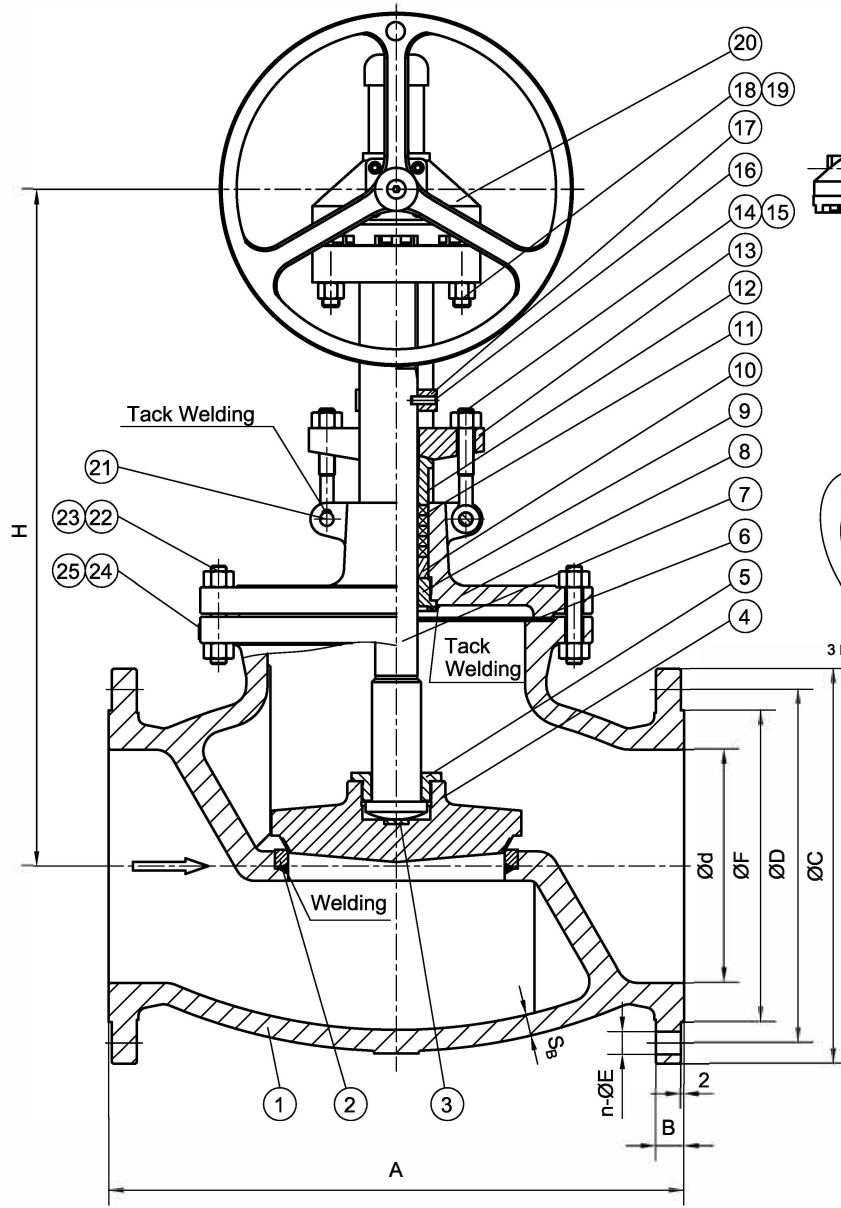

ITEM	NAME	MATERIAL	NOTE
1	BODY	ASTM A216-WCB	
2	SEAT	ASTM A105N+STL	
3	DISC WASHER	ASTM A276-420	
4	DISC	ASTM A105N+13%Cr	
5	DISC BUSHING	ASTM A276-410	
6	GASKET	304+GRAPHITE	
7	STEM	ASTM A182-F6a	
8	BONNET	ASTM A216-WCB	
9	BACKSEAT	ASTM A276-420+STL	
10	PACKING SPACER	ASTM A276-410	
11	PACKING	INCONEL600+GRAPHITE	
12	GLAND	ASTM A276-410	
13	GLAND FLANGE	ASTM A216-WCB	
14	EYE BOLT	ASTM A193-B7	
15	NUT	ASTM A194-2H	
16	ANTI-ROTATION PIN	AISI 1035	
17	STEM GUIDE	AISI 1045	
18	BOLT	ASTM A193-B7	
19	NUT	ASTM A194-2H	
20	GEAR	ASTM A216-WCB	
21	PIN	AISI 1035	
22	BOLT	ASTM A193-B7	
23	NUT	ASTM A194-2H	
24	NAMEPLATE	ASTM A240-304	
25	RIVET	ASTM A240-304	

NOTE:
1. API 622 LOW EMISSION PACKING

ITEM	FIG NO.	SIZE	UNIT	d	A	B	C	D	n	E	F	H	W	K	Sb	Weight(lbs/kgs)
01	GL300CSF8	8"	mm	203	559	41.7	380	330.2	12	25	269.9	825	610	420	17.5	655/297
		8"	in	8.0	22.0	1.64	15.0	13.0	12	1	10.62	32.46	24.02	16.54	0.69	
02	GL300CSF8	10"	mm	254	622	48.1	445	387.4	16	29	323.8	785	610	420	19.1	1003/455
		10"	in	10.0	24.5	1.89	17.5	15.25	16	1-1/8	12.75	30.91	24.02	16.54	0.75	
03	GL300CSF8	12"	mm	305	711	51	520	450.8	16	32	381	901	710	500	20.6	1596/724
		12"	in	12.0	28.0	2.0	20.5	17.75	16	1-1/4	15.00	35.47	27.95	19.69	0.81	
04	GL300CSF8	14"	mm	337	838	54	585	514.4	20	32	412.8	928	710	500	22.5	2480/1125
		14"	in	13.27	33.0	2.13	23.0	20.25	20	1-1/4	16.25	36.54	27.95	19.69	0.89	
05	GL300CSF8	16"	mm	387	864	57.6	650	571.5	20	35	469.9	1060	710	500	23.9	2315/1050
		16"	in	15.24	34.0	2.27	25.5	22.5	20	1-3/8	18.5	41.73	27.95	19.69	0.94	

TITLE:		CAST STEEL GLOBE VALVE	
		CLASS 300- API TRIM 8 -RF-GEAR OPERATED	
MATERIAL:	ASTM A216 WCB	UNITS:	Inch, mm
CLASS:	300	DATE:	4/15/19
SCALE:	N.T.S.	FIG. No.:	GL300CSF8
SIZE:	8"-16"	DRAWN BY:	F.J.
CHK'D & APR'D BY:	E.C.	REV:	1
DWG No.:			

NO.	DATE	DESCRIPTION	PRP'D	REVD	APP'D	DESIGNED	MARKING SYSTEM	INSPECTION & TEST	MATERIAL	UNITS
							MSS-SP-25	API 598	ASTM A216 WCB	Inch, mm
							ANSI B16.5	1125PSI	CLASS: 300	SCALE: N.T.S.
							ANSI B16.10	N/A	DATE: 4/15/19	FIG. No.:
							API 623	815PSI	SIZE: 8"-16"	DRAWN BY: F.J.
							API 623, ANSI B16.34		CHK'D & APR'D BY: E.C.	REV: 1