

Steamco Valves

APPLICABLE STANDARDS
 BASIC DESIGN: ASME B16.34
 FLANGE DIMENSIONS: ASME B16.1
 TEST AND INSPECTION API 598

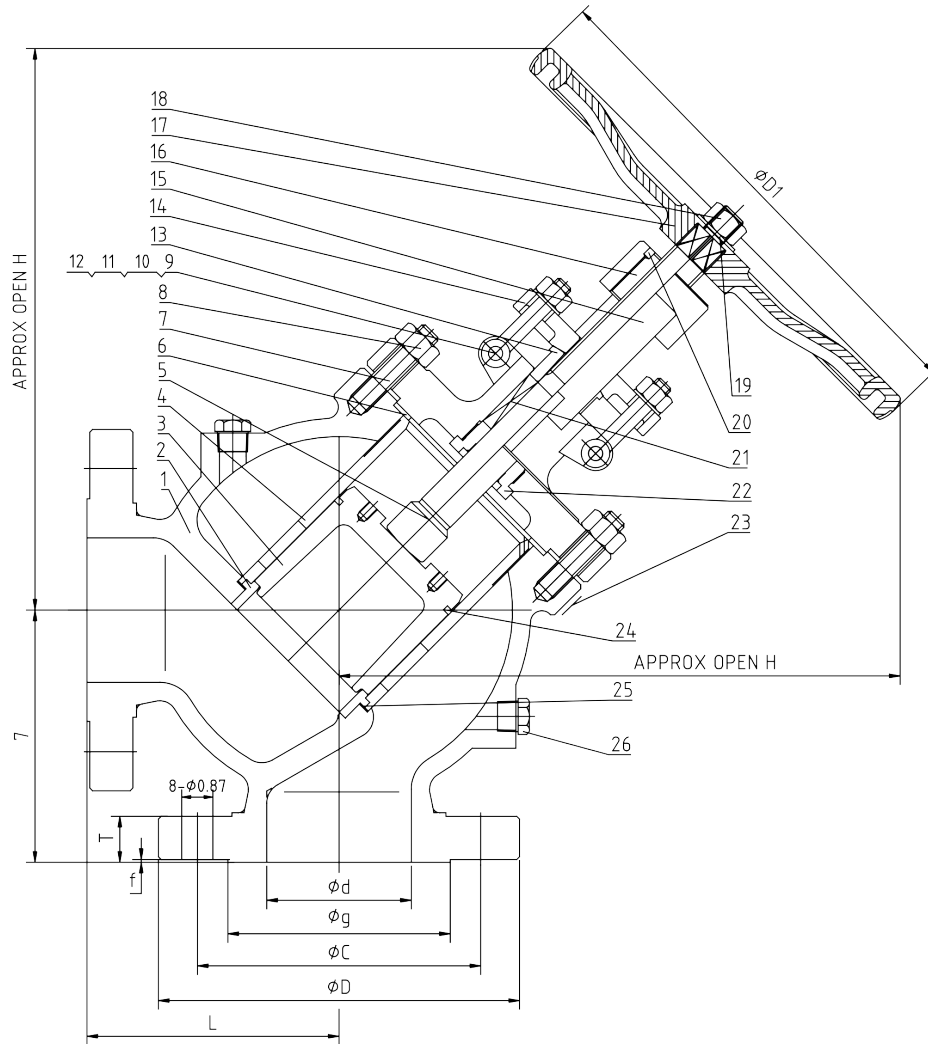

NO.	PART NAME	STANDARD	NO.	PART NAME	STANDARD
1	BODY	ASTM A216-WCB	14	GLAND FLANGE	ASTM A216-WCB
2	SEAT	ASTM A105 + STL	15	BONNET	ASTM A216-WCB
3	DISC	WCB + STL	16	YOKE SLEEVE	ASTM A439-D2
4	BUSHING	WCB	17	HAND WHEEL	QT400
5	STEM	ASTM A182-F6A	18	HAND NUT	ASTM A194-2H
6	GASKET	GRAPHITE + 304	19	WASHER	CS
7	BONNET BOLT	ASTM A193-B7	20	SET SCREWS	ASTM A29-1035
8	BONNET NUT	ASTM A194-2H	21	PACKING	GRAPHITE
9	GLAND BOLT	ASTM A193-B7	22	BONNET BUSH	ASTM A276-410
10	GLAND NUT	ASTM A194-2H	23	PLATE	ASTM A304
11	WASHER	CS	24	DISC RING	ALLOY CAST IRON
12	PIN	ASTM A29-1035	25	SEAT RING	GRAPHITE + 304
13	GLAND	ASTM A276-410	26	DRAIN PLUG	ASTM A304

SIZE	d	g	C	D	L	T	f	D1	H	N-øh	WEIGHT
3	3.00	5.00	6.62	8.25	6.26	1.12	0.06	12.40	15.90	8 x ø 0.87	137 lbs
4	4.00	6.19	7.88	10.00	7.00	1.25	0.06	14.00	17.10	8 x ø 0.87	190 lbs
6	6.00	8.50	10.63	12.60	8.75	1.38	0.06	15.06	22.40	12 x ø 0.87	387 lbs
8	8.00	10.63	13.00	15.00	10.50	1.64	0.08	23.60	28.90	12 x ø 1.00	708 lbs
10	10.00	12.75	15.25	17.50	12.24	1.90	0.08	19.70	38.00	16 x ø 1.12	975 lbs

Steamco Fig. 300ANR

300# CS FLGD ANGLE NON RETURN VALVE