

ITEM	NAME	MATERIAL
1	BODY	ASTM A216-WCB
2	SEAT	ASTM A105N+STL
3	SOLID WEDGE	ASTM A217-CA15
4	STEM	ASTM A182-F6a
5	BONNET	ASTM A216-WCB
6	RTJ GASKET	AISI 1008
7	BACKSEAT	ASTM A276-420
8	PACKING SPACER	ASTM A276-410
9	PACKING	INCONEL600+GRAPHITE
10	GLAND	ASTM A276-410
11	GLAND FLANGE	ASTM A216-WCB
12	EYE BOLT	ASTM A193-B7
13	NUT	ASTM A194-2H
14	GREASE FITTING	ASTM A283 GRC
15	HANDWHEEL	ASTM A536 60-40-18
16	HANDWHEEL NUT	AISI 1025
17	SCREW	AISI 1025
18	GLAND NUT	AISI 1025
19	STEM NUT	ASTM A439 D-2
20	PIN	AISI 1035
21	BOLT	ASTM A193-B7
22	NUT	ASTM A194-2H
23	NAMEPLATE	ASTM A240-304
24	RIVET	ASTM A240-304

NOTE:

1. API 624 QUALIFIED

ITEM	FIG NO.	SIZE	UNIT	d	A	B	C	D	n	E	F	H	W	S _b	Weight(lbs/kgs)
01	GT600CSF8	2"	mm	51	292	25.4	165	127	8	19	92.1	370	200	11.2	79/36
		2"	in	2.0	11.5	1.00	6.5	5.0	8	3/4	3.62	14.57	7.87	0.44	

					MARKING SYSTEM	MSS-SP-25	INSPECTION & TEST: API 598			MATERIAL: ASTM A216 WCB		UNITS: Inch, mm
					DIM.OF FLANGE	ANSI B16.5	SHELL	HYDRO	2225PSI	CLASS: 600	DATE: 4/15/19	SCALE: N.T.S.
					FACE TO FACE	ANSI B16.10	SEAT	AIR	80PSI	SIZE: 2"	FIG. No.: GT600CSF8	
					WALL THICKNESS	API 600	BACK SEAT	HYDRO	1630PSI	DRAWN BY: F.J.		
					DESIGNED	API 600, ANSI B16.34			CHK'D & APR'D BY: E.C.	REV: 1	DWG No.:	



Toll Free 800.582.5637 Local 310.605.0090

Here at J.J. Valve, we utilize a wide variety of products to meet your needs when it comes to industrial valves.

TITLE: CAST STEEL GATE VALVE
CLASS 600- API TRIM 8 - RF - HANDWHEEL OPERATED

NO.	DATE	DESCRIPTION	PRP'D	REV'D	APP'D
△	4/15/19	RELEASED	F.J.	E.C.	E.C.

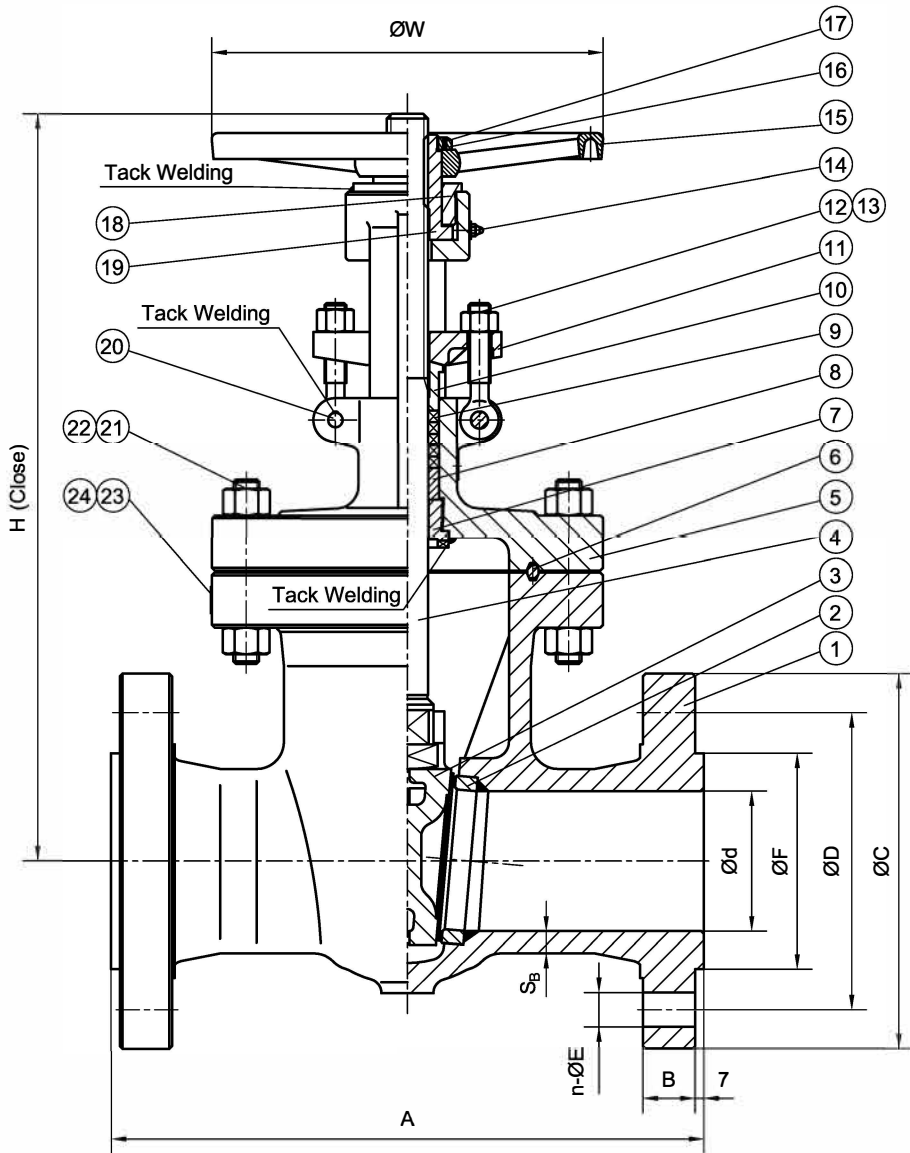

ITEM	NAME	MATERIAL
1	BODY	ASTM A216-WCB
2	SEAT	ASTM A105N+STL
3	FLEXIBLE WEDGE	ASTM A216-WCB+13%Cr
4	STEM	ASTM A182-F6a
5	BONNET	ASTM A216-WCB
6	RTJ GASKET	AISI 1008
7	BACKSEAT	ASTM A276-420
8	PACKING SPACER	ASTM A276-410
9	PACKING	INCONEL600+GRAPHITE
10	GLAND	ASTM A276-410
11	GLAND FLANGE	ASTM A216-WCB
12	EYE BOLT	ASTM A193-B7
13	NUT	ASTM A194-2H
14	GREASE FITTING	ASTM A283 GRC
15	HANDWHEEL	ASTM A536 60-40-18
16	HANDWHEEL NUT	AISI 1025
17	SCREW	AISI 1025
18	GLAND NUT	AISI 1025
19	STEM NUT	ASTM A439 D-2
20	PIN	AISI 1035
21	BOLT	ASTM A193-B7
22	NUT	ASTM A194-2H
23	NAMEPLATE	ASTM A240-304
24	RIVET	ASTM A240-304

NOTE:

- 1. FLEXIBLE WEDGE
- 2. API 624 QUALIFIED

ITEM	FIG NO.	SIZE	UNIT	d	A	B	C	D	n	E	F	H	W	Se	Weight(lbs/kgs)
01	GT600CSF8	2-1/2"	mm	64	330	28.6	190	149.2	8	22	104.8	425	250	11.9	115/52
		2-1/2"	in	2.52	13.0	1.13	7.5	5.88	8	7/8	4.12	16.73	9.84	0.47	
02	GT600CSF8	3"	mm	76	356	31.8	210	168.3	8	22	127	454	250	12.7	141/64
		3"	in	3.0	14.0	1.25	8.25	6.62	8	7/8	5.0	17.87	9.84	0.50	
03	GT600CSF8	4"	mm	102	432	38.1	275	215.9	8	25	157.2	539	300	16	260/118
		4"	in	4.02	17.0	1.5	10.75	8.5	8	1	6.19	21.22	11.81	0.63	



TITLE: CAST STEEL GATE VALVE
CLASS 600- API TRIM 8 - RF - HANDWHEEL OPERATED

					MARKING SYSTEM	MSS-SP-25	INSPECTION & TEST: API 598			MATERIAL: ASTM A216 WCB			UNITS: Inch, mm	
					DIM.OF FLANGE	ANSI B16.5	SHELL	HYDRO	2225PSI	CLASS: 600	DATE: 4/15/19	SCALE: N.T.S.		
					FACE TO FACE	ANSI B16.10	SEAT	AIR	80PSI	SIZE: 2-1/2"-4"	FIG. No.:			
					WALL THICKNESS	API 600	BACK SEAT	HYDRO	1630PSI	DRAWN BY: F.J.			GT600CSF8	
					DESIGNED	API 600, ANSI B16.34			CHK'D & APR'D BY: E.C.			REV: 1	DWG No.:	

4/15/19	RELEASED	F.J.	E.C.	E.C.	
NO.	DATE	DESCRIPTION	PRP'D	REV'D	APP'D

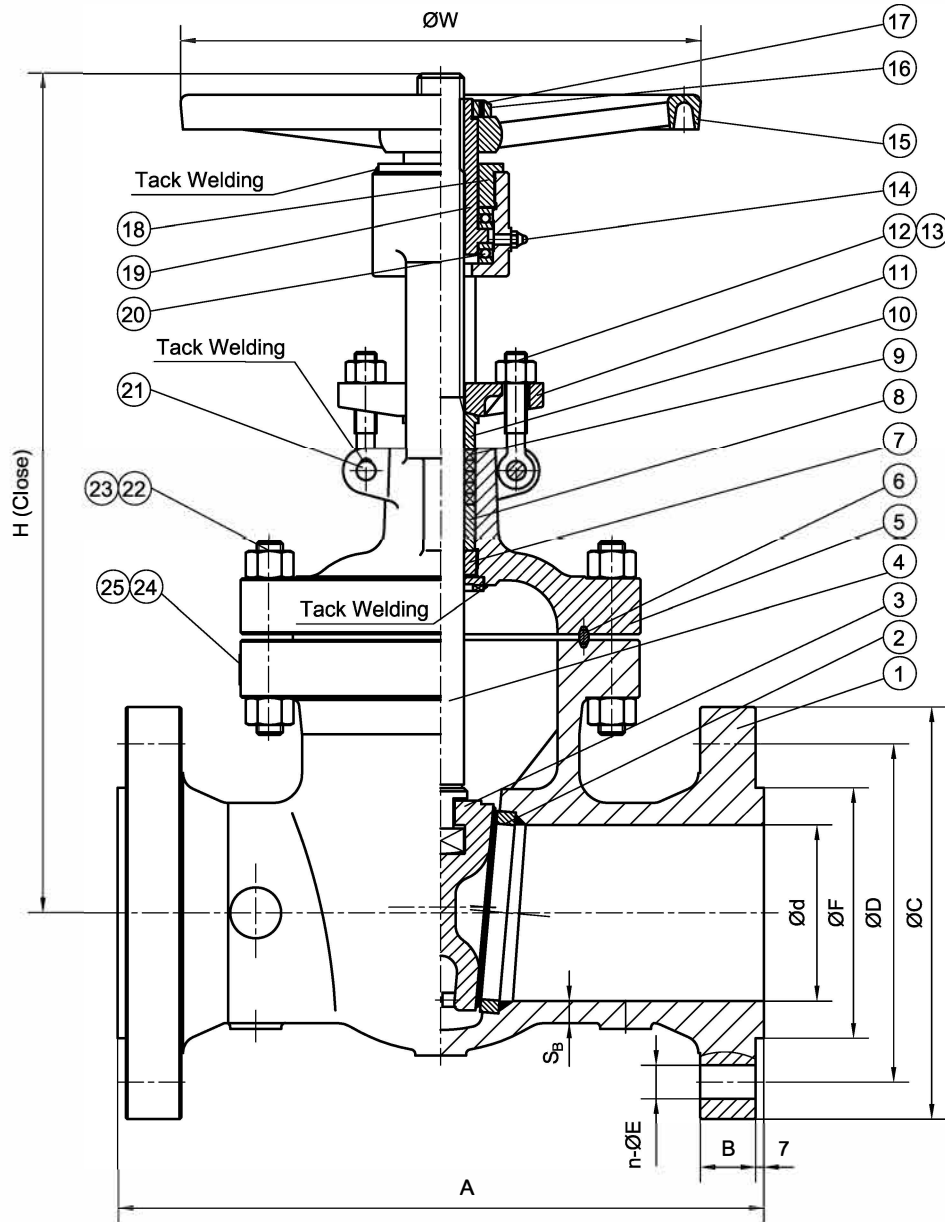

ITEM	NAME	MATERIAL
1	BODY	ASTM A216-WCB
2	SEAT	ASTM A105N+STL
3	FLEXIBLE WEDGE	ASTM A216-WCB+13%Cr
4	STEM	ASTM A182-F6a
5	BONNET	ASTM A216-WCB
6	RTJ GASKET	AISI 1008
7	BACKSEAT	ASTM A276-420
8	PACKING SPACER	ASTM A276-410
9	PACKING	INCONEL600+GRAPHITE
10	GLAND	ASTM A276-410
11	GLAND FLANGE	ASTM A216-WCB
12	EYE BOLT	ASTM A193-B7
13	NUT	ASTM A194-2H
14	GREASE FITTING	ASTM A283 GRC
15	HANDWHEEL	ASTM A536 60-40-18
16	HANDWHEEL NUT	AISI 1025
17	SCREW	AISI 1025
18	GLAND NUT	AISI 1025
19	STEM NUT	ASTM A439 D-2
20	BEARING	AISI 52100
21	PIN	AISI 1035
22	BOLT	ASTM A193-B7
23	NUT	ASTM A194-2H
24	NAMEPLATE	ASTM A240-304
25	RIVET	ASTM A240-304

NOTE:

1. FLEXIBLE WEDGE
2. API 624 QUALIFIED

ITEM	FIG NO.	SIZE	UNIT	d	A	B	C	D	n	E	F	H	W	S _B	Weight(lbs/kgs)
01	GT600CSF8	6"	mm	152	559	47.7	355	292.1	12	29	215.9	716	450	19.1	507/230
		6"	in	6.0	22.0	1.88	14.0	11.5	12	1-1/8	8.5	28.19	17.7	0.75	
02	GT600CSF8	8"	mm	200	660	55.6	420	349.2	12	32	269.9	844	500	25.4	886/402
		8"	in	7.87	26.0	2.19	16.5	13.75	12	1-1/4	10.62	33.23	19.69	1.00	
03	GT600CSF8	10"	mm	248	787	63.5	510	431.8	16	35	323.8	980	640	28.7	1345/610
		10"	in	9.76	31.0	2.50	20.0	17.0	16	1-3/8	12.75	38.58	25.2	1.13	



J.J. VALVE
Toll Free 800.582.5837 Local 310.605.0090

Here at J.J. Valve, we utilize a wide variety of products to meet your needs when it comes to industrial valves.

TITLE: CAST STEEL GATE VALVE
CLASS 600- API TRIM 8 - RF - HANDWHEEL OPERATED

MATERIAL: ASTM A216 WCB	UNITS: Inch, mm
CLASS: 600 DATE: 4/15/19	SCALE: N.T.S.
SIZE: 6"-10"	FIG. No.: GT600CSF8
DRAWN BY: F.J.	CHK'D & APR'D BY: E.C. REV: 1
NO. DATE DESCRIPTION PRPD REV'D APPD	DESIGNED API 600, ANSI B16.34

NO.	DATE	DESCRIPTION	PRPD	REV'D	APPD	DESIGNED
△	4/15/19	RELEASED	F.J.	E.C.	E.C.	

MARKING SYSTEM	MSS-SP-25	INSPECTION & TEST: API 598	MATERIAL: ASTM A216 WCB	UNITS: Inch, mm
DIM.OF FLANGE	ANSI B16.5	SHELL HYDRO 2225PSI	CLASS: 600 DATE: 4/15/19	SCALE: N.T.S.
FACE TO FACE	ANSI B16.10	SEAT AIR 80PSI	SIZE: 6"-10"	FIG. No.: GT600CSF8
WALL THICKNESS	API 600	BACK SEAT HYDRO 1630PSI	DRAWN BY: F.J.	CHK'D & APR'D BY: E.C. REV: 1
DESIGNED	API 600, ANSI B16.34			DWG No.:

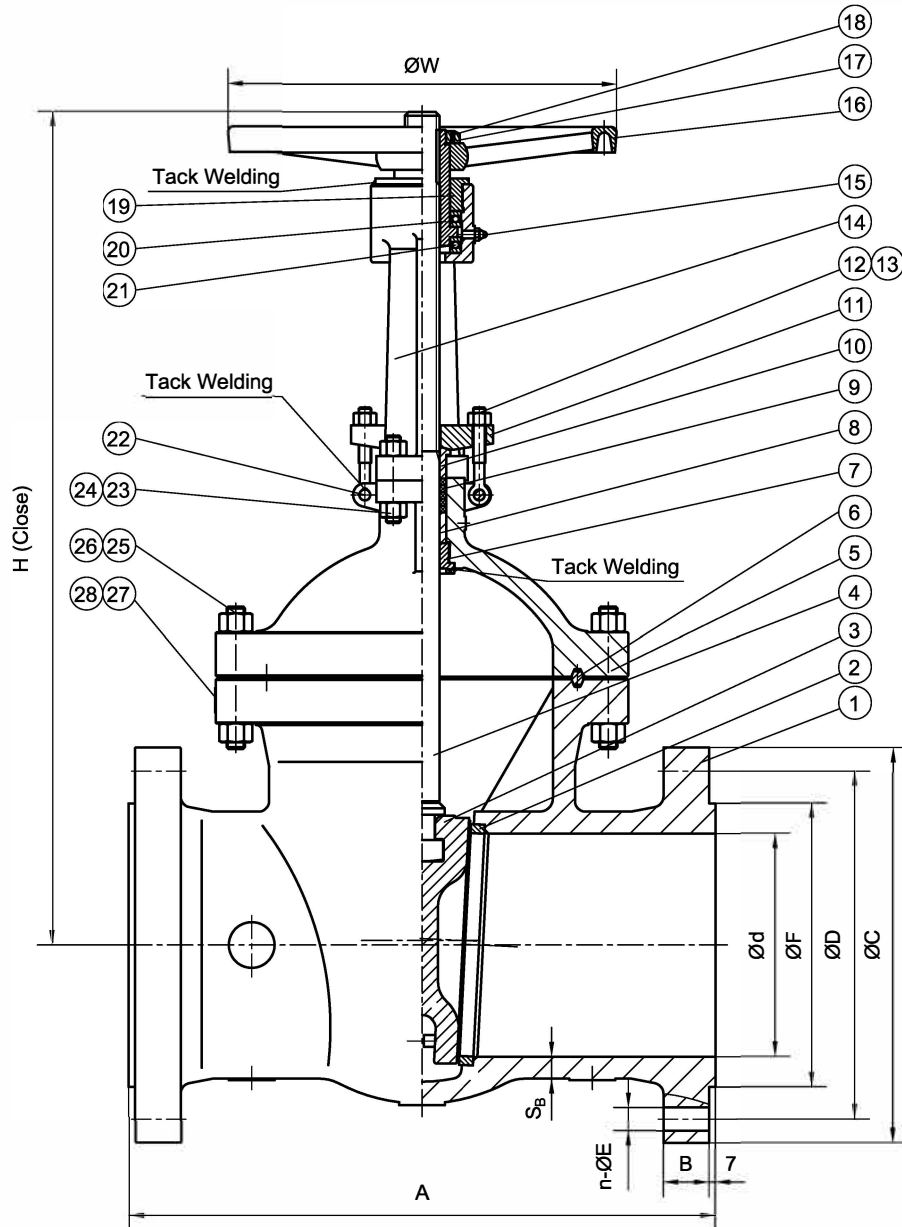

ITEM	NAME	MATERIAL
1	BODY	ASTM A216-WCB
2	SEAT	ASTM A105N+STL
3	FLEXIBLE WEDGE	ASTM A216-WCB+13%Cr
4	STEM	ASTM A182-F6a
5	BONNET	ASTM A216-WCB
6	RTJ GASKET	AISI 1008
7	BACKSEAT	ASTM A276-420
8	PACKING SPACER	ASTM A276-410
9	PACKING	INCONEL600+GRAPHITE
10	GLAND	ASTM A276-410
11	GLAND FLANGE	ASTM A216-WCB
12	EYE BOLT	ASTM A193-B7
13	NUT	ASTM A194-2H
14	YOKE	ASTM A216-WCB
15	GREASE FITTING	ASTM A283 GRC
16	HANDWHEEL	ASTM A536 60-40-18
17	HANDWHEEL NUT	AISI 1025
18	SCREW	AISI 1025
19	GLAND NUT	AISI 1025
20	STEM NUT	ASTM A439 D-2
21	BEARING	AISI 52100
22	PIN	AISI 1035
23	BOLT	ASTM A193-B7
24	NUT	ASTM A194-2H
25	BOLT	ASTM A193-B7
26	NUT	ASTM A194-2H
27	NAMEPLATE	ASTM A240-304
28	RIVET	ASTM A240-304

NOTE:

1. FLEXIBLE WEDGE
2. API 624 QUALIFIED

ITEM	FIG NO.	SIZE	UNIT	d	A	B	C	D	n	E	F	H	W	S _B	Weight(lbs/kgs)
01	GT600CSF8	12"	mm	298	838	66.7	560	489	20	35	381	1162	640	31.8	1940/880
		12"	in	11.73	33.0	2.63	22.0	19.25	20	1-3/8	15.0	45.75	25.2	1.25	

J.J. VALVE
Toll Free 800.582.5837 Local 310.605.0090
Here at J.J. Valve, we utilize a wide variety of products to meet your needs when it comes to industrial valves.

TITLE: CAST STEEL GATE VALVE
CLASS 600- API TRIM 8 - RF - HANDWHEEL OPERATED

					MARKING SYSTEM	MSS-SP-25	INSPECTION & TEST: API 598	MATERIAL: ASTM A216 WCB	UNITS: Inch, mm	
					DIM.OF FLANGE	ANSI B16.5	SHELL HYDRO 2225PSI	CLASS: 600	DATE: 4/15/19	SCALE: N.T.S.
					FACE TO FACE	ANSI B16.10	SEAT AIR 80PSI	SIZE: 12"	FIG. No.:	GT600CSF8
					WALL THICKNESS	API 600	BACK SEAT HYDRO 1630PSI	DRAWN BY: F.J.		
△	4/15/19	RELEASED	F.J.	E.C.	E.C.	DESIGNED	API 600, ANSI B16.34	CHKD & APR'D BY: E.C.	REV: 1	DWG No.:

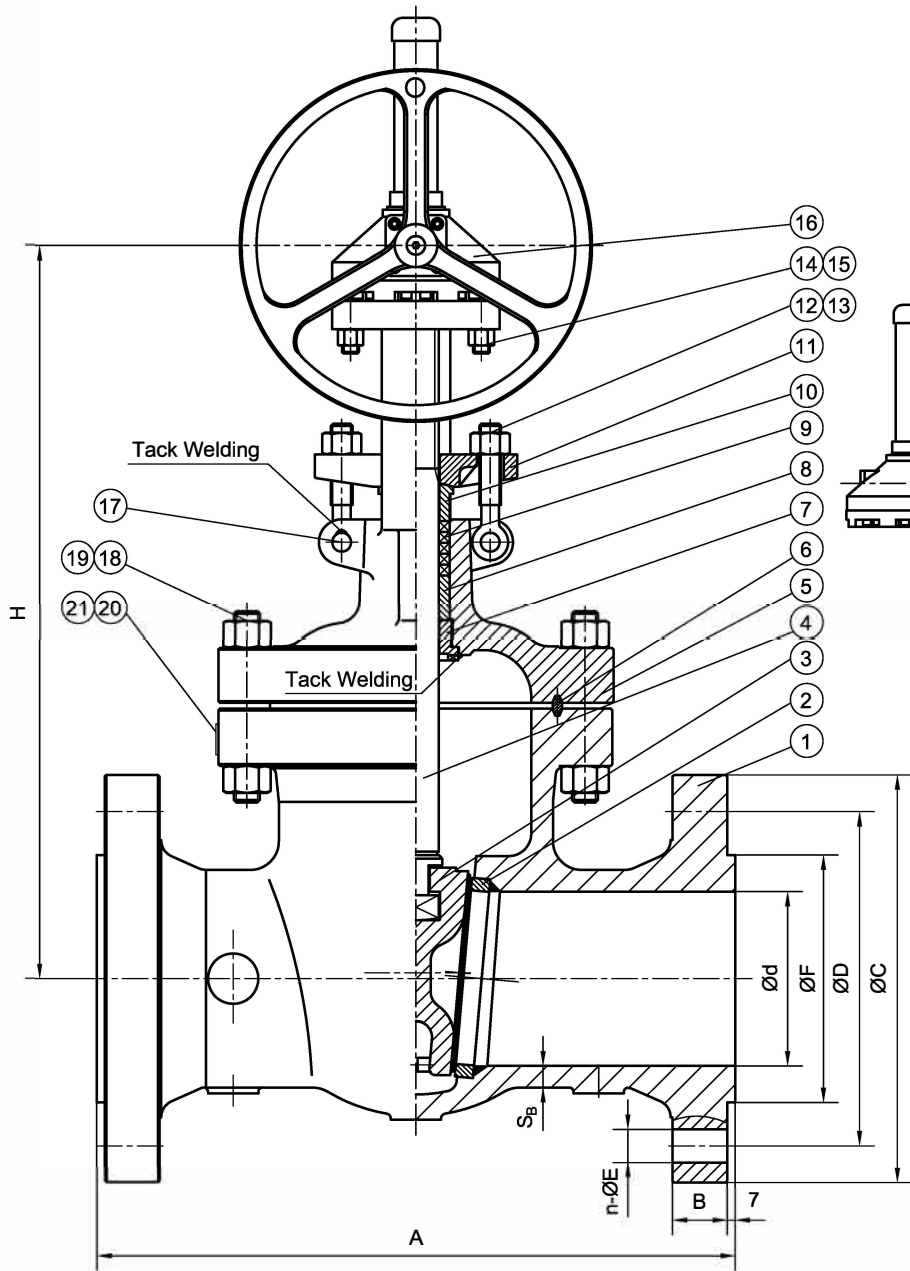

ITEM	NAME	MATERIAL
1	BODY	ASTM A216-WCB
2	SEAT	ASTM A105N+STL
3	FLEXIBLE WEDGE	ASTM A216-WCB+13%Cr
4	STEM	ASTM A182-F6a
5	BONNET	ASTM A216-WCB
6	RTJ GASKET	AISI 1008
7	BACKSEAT	ASTM A276-420
8	PACKING SPACER	ASTM A276-410
9	PACKING	INCONEL600+GRAPHITE
10	GLAND	ASTM A276-410
11	GLAND FLANGE	ASTM A216-WCB
12	EYE BOLT	ASTM A193-B7
13	NUT	ASTM A194-2H
14	BOLT	ASTM A193-B7
15	NUT	ASTM A194-2H
16	GEAR	ASTM A216-WCB
17	PIN	AISI 1035
18	BOLT	ASTM A193-B7
19	NUT	ASTM A194-2H
20	NAMEPLATE	ASTM A240-304
21	RIVET	ASTM A240-304

NOTE:
 1. FLEXIBLE WEDGE
 2. API 624 QUALIFIED

ITEM	FIG NO.	SIZE	UNIT	d	A	B	C	D	n	E	F	H	W	K	S _B	Weight(lbs/kgs)
01	GT600CSF8	6"	mm	152	559	47.7	355	292.1	12	29	215.9	678	460	345	19.1	551/250
		6"	in	6.0	22.0	1.88	14.0	11.5	12	1-1/8	8.5	26.7	18.11	13.58	0.75	
02	GT600CSF8	8"	mm	200	660	55.6	420	349.2	12	32	269.9	842	460	345	25.4	886/402
		8"	in	7.87	26.0	2.19	16.5	13.75	12	1-1/4	10.62	33.15	18.11	13.58	1.00	
03	GT600CSF8	10"	mm	248	787	63.5	510	431.8	16	35	323.8	978	610	420	28.7	1532/695
		10"	in	9.76	31.0	2.50	20.0	17.0	16	1-3/8	12.75	38.5	24.0	16.53	1.13	



J.J. VALVE
 Toll Free 800.582.5837 Local 310.605.0090

Here at J.J. Valve, we utilize a wide variety of products to meet your needs when it comes to industrial valves.

TITLE: CAST STEEL GATE VALVE
 CLASS 600- API TRIM 8 - RF - GEAR OPERATED

MARKING SYSTEM	MSS-SP-25	INSPECTION & TEST: API 598	MATERIAL: ASTM A216 WCB	UNITS: Inch, mm
DIM.OF FLANGE	ANSI B16.5	SHELL HYDRO 2225PSI	CLASS: 600	DATE: 4/15/19
FACE TO FACE	ANSI B16.10	SEAT AIR 80PSI	SIZE: 6"-10"	SCALE: N.T.S.
WALL THICKNESS	API 600	BACKSEAT HYDRO 1630PSI	DRAWN BY: F.J.	FIG. No.: GT600CSF8-GO
NO.	DATE	DESCRIPTION	PRP'D	REV'D
	4/15/19	RELEASED	F.J.	E.C.

DESIGNED: API 600, ANSI B16.34
 CHK'D & APR'D BY: E.C. REV: 1 DWG No.:

NO.	DATE	DESCRIPTION	PRP'D	REV'D	APP'D	DESIGNED
	4/15/19	RELEASED	F.J.	E.C.	E.C.	API 600, ANSI B16.34

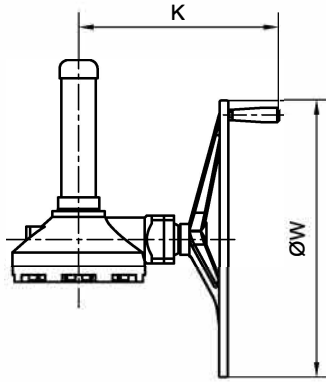
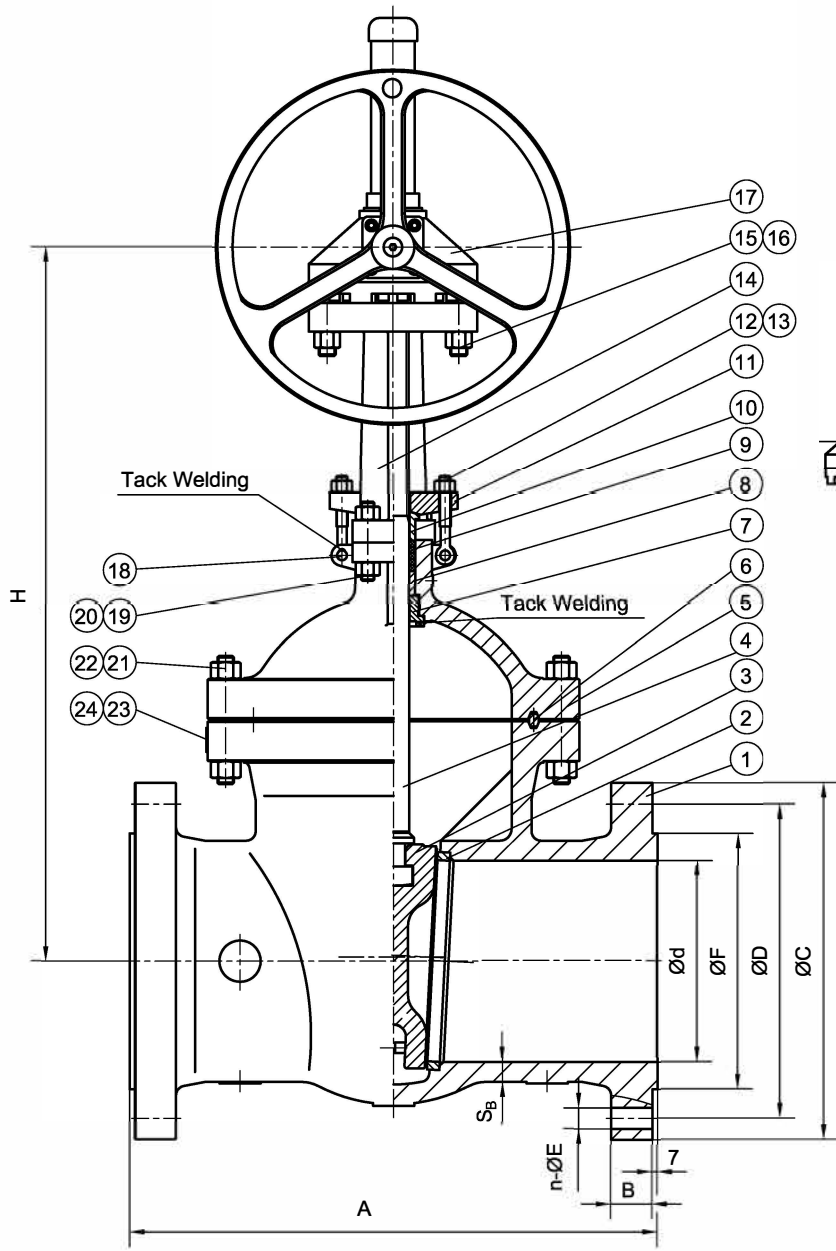

ITEM	NAME	MATERIAL
1	BODY	ASTM A216-WCB
2	SEAT	ASTM A105N+STL
3	FLEXIBLE WEDGE	ASTM A216-WCB+13%Cr
4	STEM	ASTM A182-F6a
5	BONNET	ASTM A216-WCB
6	RTJ GASKET	AISI 1008
7	BACKSEAT	ASTM A276-420
8	PACKING SPACER	ASTM A276-410
9	PACKING	INCONEL600+GRAPHITE
10	GLAND	ASTM A276-410
11	GLAND FLANGE	ASTM A216-WCB
12	EYE BOLT	ASTM A193-B7
13	NUT	ASTM A194-2H
14	YOKE	ASTM A216-WCB
15	BOLT	ASTM A193-B7
16	NUT	ASTM A194-2H
17	GEAR	ASTM A216-WCB
18	PIN	AISI 1035
19	BOLT	ASTM A193-B7
20	NUT	ASTM A194-2H
21	BOLT	ASTM A193-B7
22	NUT	ASTM A194-2H
23	NAMEPLATE	ASTM A240-304
24	RIVET	ASTM A240-304

- NOTE:
1. FLEXIBLE WEDGE
 2. API 624 QUALIFIED

ITEM	FIG NO.	SIZE	UNIT	d	A	B	C	D	n	E	F	H	W	K	S _b	Weight(lbs/kgs)
01	GT600CSF8	12"	mm	298	838	66.7	560	489	20	35	381	1141	610	420	31.8	1940/880
		12"	in	11.73	33.0	2.63	22.0	19.25	20	1-3/8	15.0	44.92	24.0	16.53	1.25	
02	GT600CSF8	14"	mm	327	889	69.9	605	527	20	38	412.8	1297	710	500	35.1	2712/1230
		14"	in	12.87	35.0	2.75	23.75	20.75	20	1-1/2	16.25	51.06	27.95	19.69	1.38	
03	GT600CSF8	16"	mm	375	991	76.2	685	603.2	20	41	469.9	1398	710	505	38.1	3373/1530
		16"	in	14.76	39.0	3.00	27.0	23.75	20	1-5/8	18.5	55.04	27.95	19.88	1.5	

Toll Free 800.582.5837 Local 310.605.0090

Here at J.J. Valve, we utilize a wide variety of products to meet your needs when it comes to industrial valves.

TITLE: CAST STEEL GATE VALVE
CLASS 600- API TRIM 8 - RF - GEAR OPERATED

MARKING SYSTEM	MSS-SP-25	INSPECTION & TEST:	API 598	MATERIAL:	ASTM A216 WCB	UNITS:	Inch, mm			
DIM.OF FLANGE	ANSI B16.5	SHELL	HYDRO	2225PSI	CLASS:	600	DATE:	4/15/19	SCALE:	N.T.S.
FACE TO FACE	ANSI B16.10	SEAT	AIR	80PSI	SIZE:	12"-16"	FIG. No.:	GT600CSF8GO		
WALL THICKNESS	API 600	BACK SEAT	HYDRO	1630PSI	DRAWN BY:	F.J.				
DESIGNED	API 600, ANSI B16.34	CHK'D & APR'D BY:	E.C.	REV:	1	DWG No.:				

4/15/19	RELEASED	F.J.	E.C.	E.C.	
NO.	DATE	DESCRIPTION	PRP'D	REV'D	APP'D

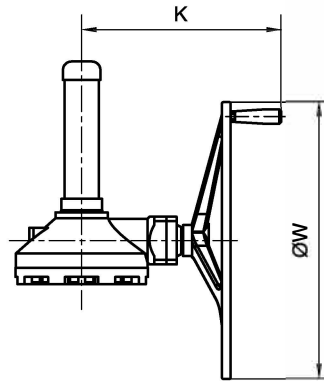
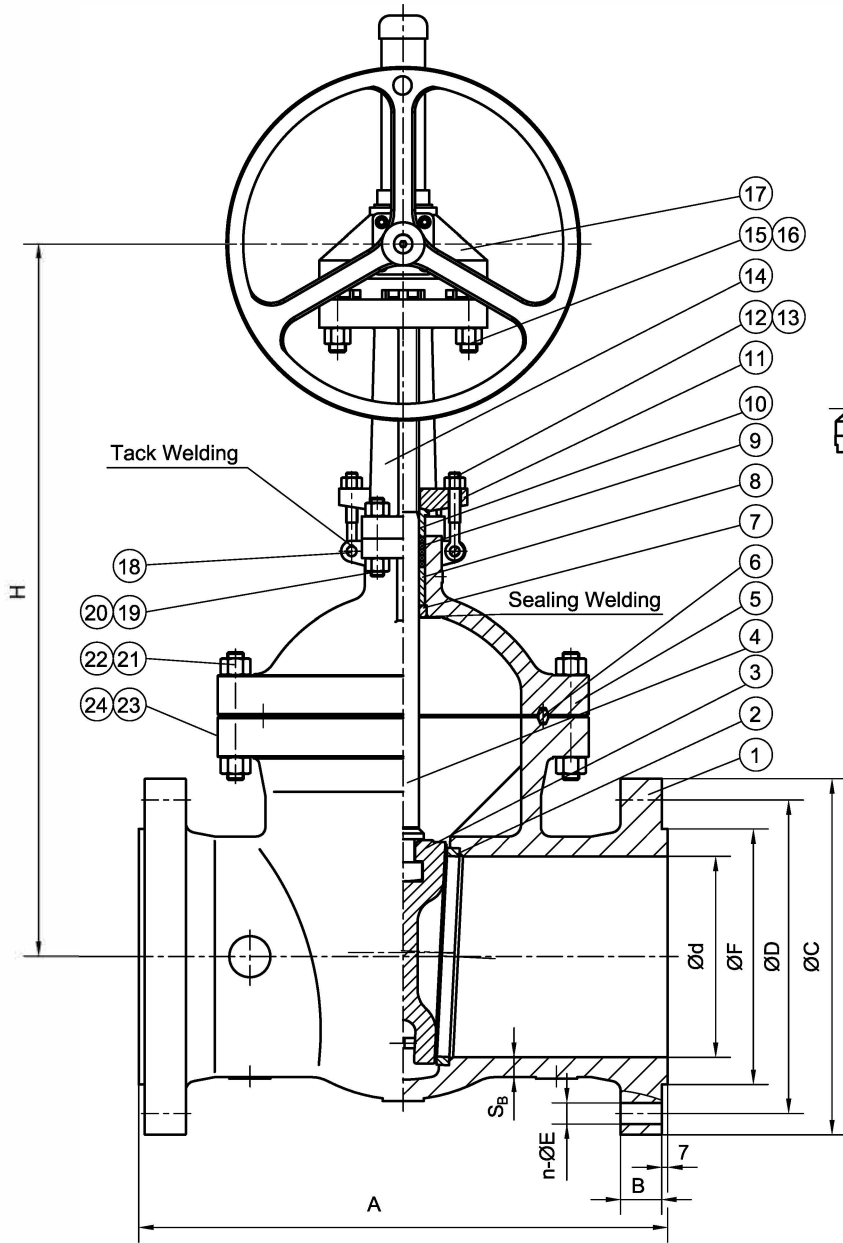

ITEM	NAME	MATERIAL
1	BODY	ASTM A216-WCB
2	SEAT	ASTM A105N+STL
3	FLEXIBLE WEDGE	ASTM A216-WCB+13%Cr
4	STEM	ASTM A182-F6a
5	BONNET	ASTM A216-WCB
6	RTJ GASKET	AISI 1008
7	BACKSEAT	ASTM A276-420
8	PACKING SPACER	ASTM A276-410
9	PACKING	INCONEL600+GRAPHITE
10	GLAND	ASTM A276-410
11	GLAND FLANGE	ASTM A216-WCB
12	EYE BOLT	ASTM A193-B7
13	NUT	ASTM A194-2H
14	YOKE	ASTM A216-WCB
15	BOLT	ASTM A193-B7
16	NUT	ASTM A194-2H
17	GEAR	ASTM A216-WCB
18	PIN	AISI 1035
19	BOLT	ASTM A193-B7
20	NUT	ASTM A194-2H
21	BOLT	ASTM A193-B7
22	NUT	ASTM A194-2H
23	NAMEPLATE	ASTM A240-304
24	RIVET	ASTM A240-304

NOTE:

- 1. FLEXIBLE WEDGE
- 2. API 624 QUALIFIED

ITEM	FIG NO.	SIZE	UNIT	d	A	B	C	D	n	E	F	H	W	K	S _b	Weight(lbs/kgs)
01	GT600CSF8	18"	mm	419	1092	82.6	745	654	20	45	533.4	1493	710	500	41.4	4475/2030
		18"	in	16.5	43.0	3.25	29.25	25.75	20	1-3/4	21.0	58.78	27.95	19.69	1.63	
02	GT600CSF8	20"	mm	464	1194	88.9	815	723.9	24	45	584.2	1648	710	580	45	6283/2850
		20"	in	18.27	47.0	3.5	32.0	28.5	24	1-3/4	23.0	64.88	27.95	22.83	1.77	
03	GT600CSF8	24"	mm	559	1397	101.6	940	838.2	24	51	692.2	1945	800	610	50.8	7981/3620
		24"	in	22.0	55.0	4.00	37.0	33.0	24	2	27.25	76.57	31.5	24.0	2.0	

				MARKING SYSTEM	MSS-SP-25	INSPECTION & TEST: API 598			MATERIAL: ASTM A216 WCB			UNITS: Inch, mm	
				DIM.OF FLANGE	ANSI B16.5	SHELL	HYDRO	2225PSI	CLASS: 600	DATE: 4/15/19	SCALE: N.T.S.		
				FACE TO FACE	ANSI B16.10	SEAT	AIR	80PSI	SIZE: 18"-24"	FIG. No.:			
				WALL THICKNESS	API 600	BACK SEAT	HYDRO	1630PSI	DRAWN BY: F.J.		GT600CSF8GO		
NO.	DATE	DESCRIPTION	PRP'D	REV'D	APP'D	DESIGNED	API 600, ANSI B16.34		CHK'D & APR'D BY: E.C.	REV: 1	DWG No.:		

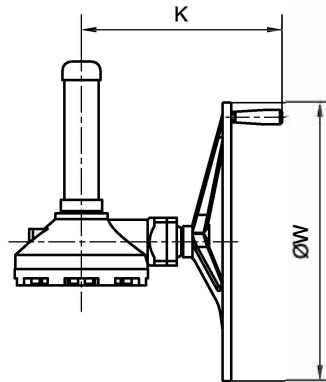
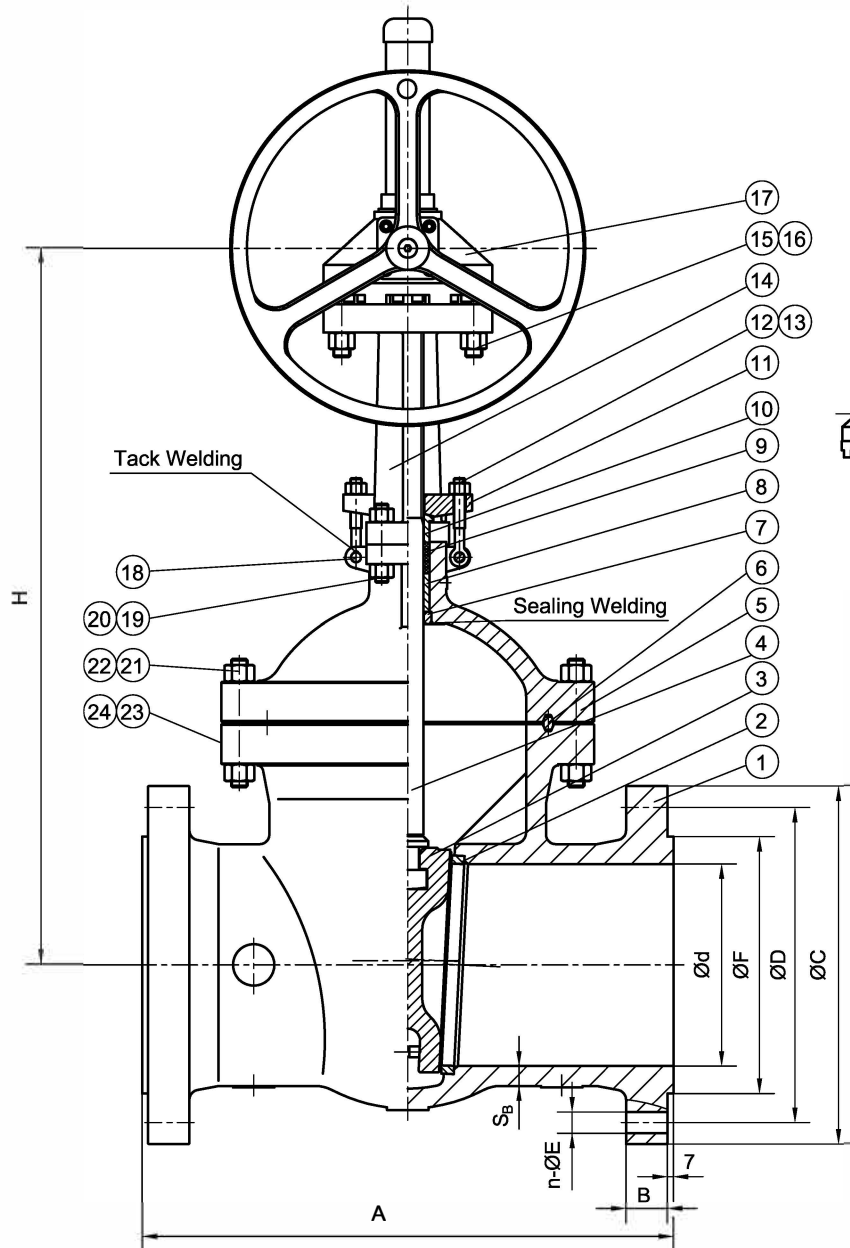

ITEM	NAME	MATERIAL
1	BODY	ASTM A216-WCB
2	SEAT	ASTM A105N+STL
3	FLEXIBLE WEDGE	ASTM A216-WCB+13%Cr
4	STEM	ASTM A182-F6a
5	BONNET	ASTM A216-WCB
6	RTJ GASKET	AISI 1008
7	BACKSEAT	ASTM A276-420
8	PACKING SPACER	ASTM A276-410
9	PACKING	INCONEL600+GRAPHITE
10	GLAND	ASTM A276-410
11	GLAND FLANGE	ASTM A216-WCB
12	EYE BOLT	ASTM A193-B7
13	NUT	ASTM A194-2H
14	YOKE	ASTM A216-WCB
15	BOLT	ASTM A193-B7
16	NUT	ASTM A194-2H
17	GEAR	ASTM A216-WCB
18	PIN	AISI 1035
19	BOLT	ASTM A193-B7
20	NUT	ASTM A194-2H
21	BOLT	ASTM A193-B7
22	NUT	ASTM A194-2H
23	NAMEPLATE	ASTM A240-304
24	RIVET	ASTM A240-304

NOTE:

1. API 622 LOW EMISSION PACKING

ITEM	FIG NO.	SIZE	UNIT	d	A	B	C	D	n	E	F	H	W	K	S _B	Weight(lbs/kgs)
01	GT600CSF8	30"	mm	695	1651	114.3	1130	1022.5	28	54	857	2418	1000	760	56.2	15311/6945
		30"	in	27.37	65.0	4.5	44.5	40.25	28	2-1/8	33.75	95.2	39.37	29.92	2.21	

					MARKING SYSTEM	MSS-SP-25	INSPECTION & TEST: API 598			MATERIAL: ASTM A216 WCB		UNITS: Inch, mm	
					DIM.OF FLANGE	ANSI B16.47a	SHELL	HYDRO	2225PSI	CLASS: 600	DATE: 4/15/19	SCALE: N.T.S.	
					FACE TO FACE	ANSI B16.10	SEAT	AIR	80PSI	SIZE: 30"	FIG. No.: GT600CSF8 G0		
					WALL THICKNESS	API 600	BACK SEAT	HYDRO	1630PSI	DRAWN BY: F.J.			
					DESIGNED	API 600, ANSI B16.34			CHK'D & APR'D BY: E.C.		REV: 1	DWG No.:	
▲	4/15/19	RELEASED	F.J.	E.C.	E.C.								
NO.	DATE	DESCRIPTION	PRP'D	REV'D	APP'D								

Toll Free 800.582.5837 Local 310.605.0090

Here at J.J. Valve, we utilize a wide variety of products to meet your needs when it comes to Industrial valves.

TITLE: CAST STEEL GATE VALVE
CLASS 600- API TRIM 8 - RF - GEAR OPERATED