

ITEM	NAME	MATERIAL
1	BODY	ASTM A216-WCB
2	SEAT	ASTM A105N+STL
3	SOLID WEDGE	ASTM A216-WCB+13%Cr
4	STEM	ASTM A182-F6a
5	BONNET	ASTM A216-WCB
6	RTJ GASKET	AISI 1008
7	BACKSEAT	ASTM A276-420
8	PACKING SPACER	ASTM A276-410
9	PACKING	INCONEL600+GRAPHITE
10	GLAND	ASTM A276-410
11	GLAND FLANGE	ASTM A216-WCB
12	EYE BOLT	ASTM A193-B7
13	NUT	ASTM A194-2H
14	GREASE FITTING	ASTM A283 GRC
15	HANDWHEEL	ASTM A536 60-40-18
16	HANDWHEEL NUT	AISI 1025
17	SCREW	AISI 1025
18	GLAND NUT	AISI 1025
19	STEM NUT	ASTM A439 D-2
20	BEARING	AISI 52100
21	PIN	AISI 1035
22	BOLT	ASTM A193-B7
23	NUT	ASTM A194-2H
24	NAMEPLATE	ASTM A240-304
25	RIVET	ASTM A240-304

NOTE:

1. API 624 QUALIFIED

ITEM	FIG NO.	SIZE	UNIT	d	A	B	C	D	n	E	F	H	W	S <sub>B</sub>	Weight(lbs/kgs)
01	GT900CSF8	2"	mm	48	368	38.1	215	165.1	8	25	92.1	430	250	19.1	174/79
		2"	in	1.89	14.5	1.5	8.5	6.5	8	1	3.62	16.93	9.84	0.75	



TITLE:				CAST STEEL GATE VALVE			
				CLASS 900- API TRIM 8 - RF - HANDWHEEL OPERATED			
MARKING SYSTEM		MSS-SP-25	INSPECTION & TEST: API 598		MATERIAL: ASTM A216 WCB		UNITS: Inch, mm
DIM.OF FLANGE		ANSI B16.5	SHELL	HYDRO	3350PSI	CLASS: 900	DATE: 4/15/19
FACE TO FACE		ANSI B16.10	SEAT	AIR	80PSI	SIZE: 2"	FIG. No.:
WALL THICKNESS		API 600	BACK SEAT	HYDRO	2445PSI	DRAWN BY: F.J.	
DESIGNED		API 600, ANSI B16.34		CHK'D & APR'D BY: E.C.		REV: 1	DWG No.:

NO.	DATE	DESCRIPTION	PRP'D	REV'D	APP'D
4/15/19	RELEASED	F.J.	E.C.	E.C.	

**GT900CSF8**

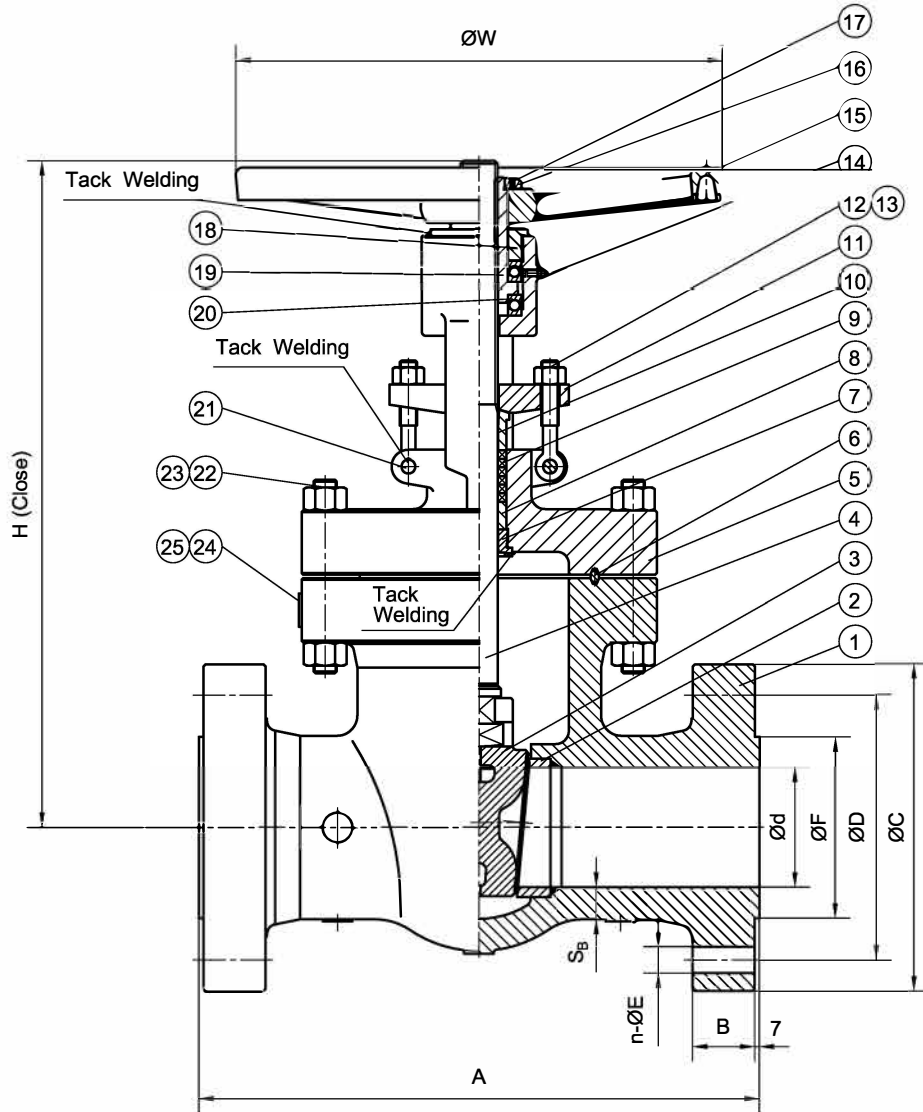

ITEM	NAME	MATERIAL
1	BODY	ASTM A216-WCB
2	SEAT	ASTM A105N+STL
3	FLEXIBLE WEDGE	ASTM A216-WCB+13%Cr
4	STEM	ASTM A182-F6a
5	BONNET	ASTM A216-WCB
6	RTJ GASKET	AISI 1008
7	BACKSEAT	ASTM A276-420
8	PACKING SPACER	ASTM A276-410
9	PACKING	INCONEL600+GRAPHITE
10	GLAND	ASTM A276-410
11	GLAND FLANGE	ASTM A216-WCB
12	EYE BOLT	ASTM A193-B7
13	NUT	ASTM A194-2H
14	GREASE FITTING	ASTM A283 GRC
15	HANDWHEEL	ASTM A536 60-40-18
16	HANDWHEEL NUT	AISI 1025
17	SCREW	AISI 1025
18	GLAND NUT	AISI 1025
19	STEM NUT	ASTM A439 D-2
20	BEARING	AISI 52100
21	PIN	AISI 1035
22	BOLT	ASTM A193-B7
23	NUT	ASTM A194-2H
24	NAMEPLATE	ASTM A240-304
25	RIVET	ASTM A240-304

NOTE:

1. FLEXIBLE WEDGE
2. API 624 QUALIFIED

ITEM	FIG NO.	SIZE	UNIT	d	A	B	C	D	n	E	F	H	W	S <sub>B</sub>	Weight(lbs/kgs)
01	GT900CSF8	2-1/2"	mm	57	419	41.3	245	190.5	8	29	104.8	490	300	22.5	203/92
		2-1/2"	in	2.24	16.5	1.62	9.62	7.5	8	1-1/8	4.12	19.29	11.8	0.88	
02	GT900CSF8	3"	mm	73	381	38.1	240	190.5	8	25	127	520	350	19.1	216/98
		3"	in	2.87	15.0	1.5	9.5	7.5	8	1	5.0	20.47	13.78	0.75	



**J.J. VALVE**  
Toll Free 800.582.5837 Local 310.605.0090

Here at J.J. Valve, we utilize a wide variety of products to meet your needs when it comes to industrial valves.

TITLE: CAST STEEL GATE VALVE  
CLASS 900- API TRIM 8 - RF - HANDWHEEL OPERATED

MATERIAL: ASTM A216 WCB	UNITS: Inch, mm
CLASS: 900 DATE: 4/15/19	SCALE: N.T.S.
FACE TO FACE ANSI B16.10 SEAT AIR 80PSI	SIZE: 2-1/2"-3"
WALL THICKNESS API 600 BACK SEAT HYDRO 2445PSI	DRAWN BY: F.J.
NO. DATE DESCRIPTION PRP'D REV'D APP'D DESIGNED API 600, ANSI B16.34	CHK'D & APR'D BY: E.C. REV: 1

**GT900CSF8**

NO.	DATE	DESCRIPTION	PRP'D	REV'D	APP'D	DESIGNED
1	4/15/19	RELEASED				

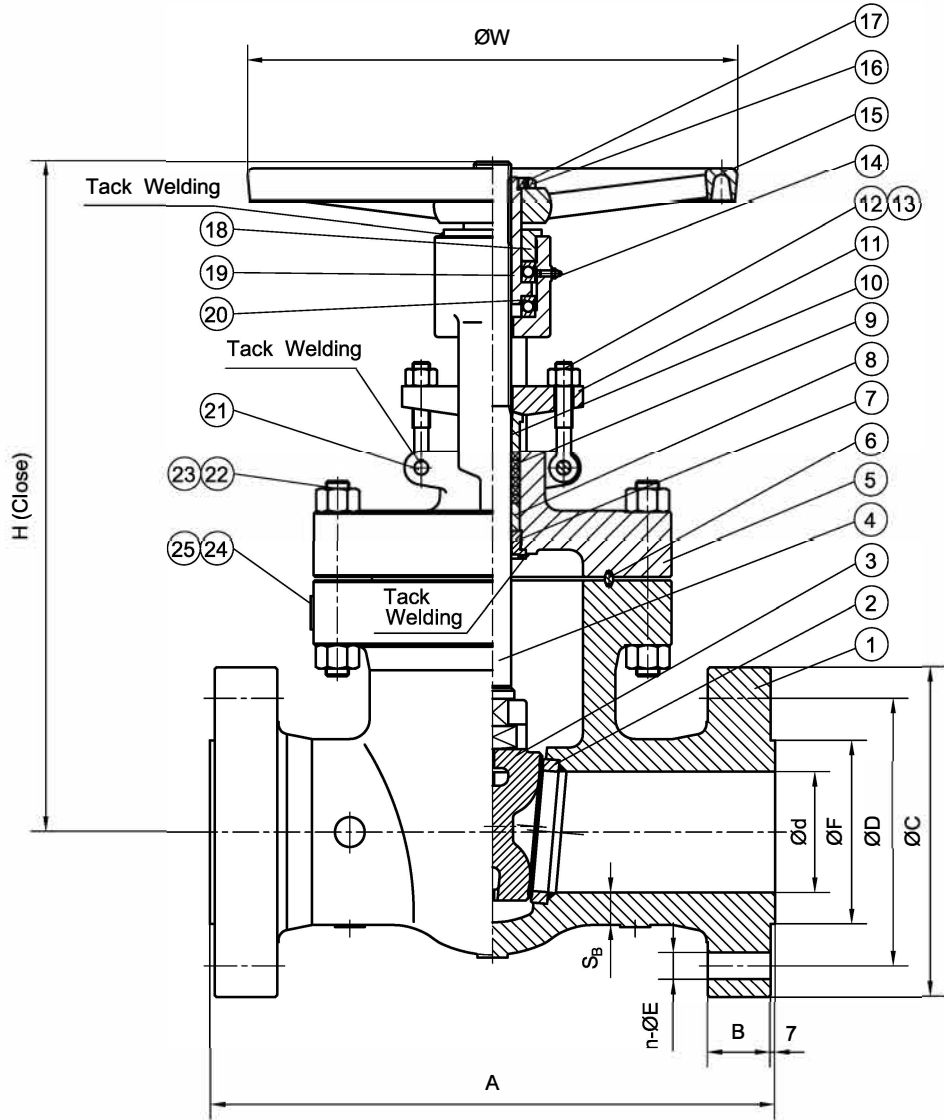

ITEM	NAME	MATERIAL
1	BODY	ASTM A216-WCB
2	SEAT	ASTM A105N+STL
3	FLEXIBLE WEDGE	ASTM A216-WCB+13%Cr
4	STEM	ASTM A182-F6a
5	BONNET	ASTM A216-WCB
6	RTJ GASKET	AISI 1008
7	BACKSEAT	ASTM A276-420
8	PACKING SPACER	ASTM A276-410
9	PACKING	INCONEL600+GRAPHITE
10	GLAND	ASTM A276-410
11	GLAND FLANGE	ASTM A216-WCB
12	EYE BOLT	ASTM A193-B7
13	NUT	ASTM A194-2H
14	GREASE FITTING	ASTM A283 GRC
15	HANDWHEEL	ASTM A536 60-40-18
16	HANDWHEEL NUT	AISI 1025
17	SCREW	AISI 1025
18	GLAND NUT	AISI 1025
19	STEM NUT	ASTM A439 D-2
20	BEARING	AISI 52100
21	PIN	AISI 1035
22	BOLT	ASTM A193-B7
23	NUT	ASTM A194-2H
24	NAMEPLATE	ASTM A240-304
25	RIVET	ASTM A240-304

NOTE:

- 1. FLEXIBLE WEDGE
- 2. API 624 QUALIFIED

ITEM	FIG NO.	SIZE	UNIT	d	A	B	C	D	n	E	F	H	W	S <sub>B</sub>	Weight(lbs/kgs)
01	GT900CSF8	4"	mm	99	457	44.5	290	235	8	32	157.2	573	350	21.3	342/155
		4"	in	3.9	18.0	1.75	11.5	9.25	8	1-1/4	6.19	22.56	13.78	0.84	

Toll Free 800.582.5837 Local 310.605.0090

Here at J.J. Valve, we utilize a wide variety of products to meet your needs when it comes to industrial valves.

TITLE:		CAST STEEL GATE VALVE	
		CLASS 900- API TRIM 8 - RF - HANDWHEEL OPERATED	
MATERIAL: ASTM A216 WCB	UNITS: Inch, mm		
CLASS: 900	DATE: 4/15/19	SCALE: N.T.S.	
SIZE: 4"	DRAWN BY: F.J.		FIG. No.: GT900CSFB
CHK'D & APR'D BY: E.C.	REV: 1	DWG No.:	

NO.	DATE	DESCRIPTION	PRP'D	REV'D	APP'D	DESIGNED	MARKING SYSTEM	MSS-SP-25	INSPECTION & TEST: API 598	WALL THICKNESS	HYDRO	3350PSI	80PSI	2445PSI
△	4/15/19	RELEASED	F.J.	E.C.	E.C.					API 600	BACK SEAT	HYDRO	2445PSI	
										API 600, ANSI B16.34				

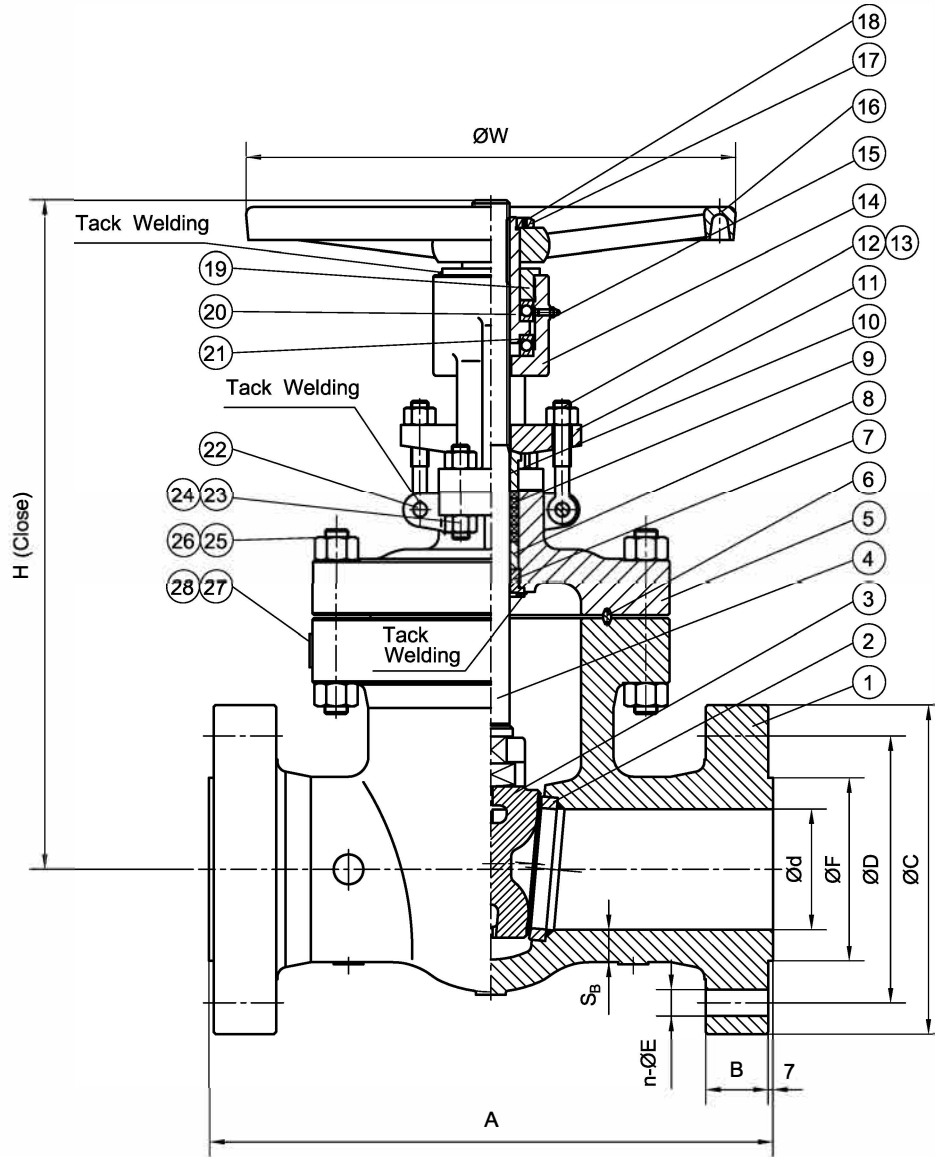

ITEM	NAME	MATERIAL
1	BODY	ASTM A216-WCB
2	SEAT	ASTM A105N+STL
3	FLEXIBLE WEDGE	ASTM A216-WCB+13%Cr
4	STEM	ASTM A182-F6a
5	BONNET	ASTM A216-WCB
6	RTJ GASKET	AISI 1008
7	BACKSEAT	ASTM A276-420
8	PACKING SPACER	ASTM A276-410
9	PACKING	INCONEL600+GRAPHITE
10	GLAND	ASTM A276-410
11	GLAND FLANGE	ASTM A216-WCB
12	EYE BOLT	ASTM A193-B7
13	NUT	ASTM A194-2H
14	YOKE	ASTM A216-WCB
15	GREASE FITTING	ASTM A283 GRC
16	HANDWHEEL	ASTM A536 60-40-18
17	HANDWHEEL NUT	AISI 1025
18	SCREW	AISI 1025
19	GLAND NUT	AISI 1025
20	STEM NUT	ASTM A439 D-2
21	BEARING	AISI 52100
22	PIN	AISI 1035
23	BOLT	ASTM A193-B7
24	NUT	ASTM A194-2H
25	BOLT	ASTM A193-B7
26	NUT	ASTM A194-2H
27	NAMEPLATE	ASTM A240-304
28	RIVET	ASTM A240-304

NOTE:

- 1. FLEXIBLE WEDGE
- 2. API 624 QUALIFIED

ITEM	FIG NO.	SIZE	UNIT	d	A	B	C	D	n	E	F	H	W	S <sub>b</sub>	Weight(lbs/kgs)
01	GT900CSF8	6"	mm	146	610	55.6	380	317.5	12	32	215.9	765	500	26.2	783/355
		6"	in	5.75	24.0	2.19	15.0	12.5	12	1-1/4	8.5	30.12	19.69	1.03	
02	GT900CSF8	8"	mm	191	737	63.5	470	393.7	12	38	269.9	890	640	31.8	1367/620
		8"	in	7.52	29.0	2.5	18.5	15.5	12	1-1/2	10.62	35.0	25.2	1.25	



**J.J. VALVE**

Toll Free 800.582.5837 Local 310.605.0090

Here at J.J. Valve, we utilize a wide variety of products to meet your needs when it comes to industrial valves.

TITLE: CAST STEEL GATE VALVE  
CLASS 900- API TRIM 8 - RF - HANDWHEEL OPERATED

					MARKING SYSTEM	MSS-SP-25	INSPECTION & TEST: API 598			MATERIAL: ASTM A216 WCB			UNITS: Inch, mm	
					DIM.OF FLANGE	ANSI B16.5	SHELL	HYDRO	3350PSI	CLASS: 900	DATE: 4/15/19	SCALE: N.T.S.		
					FACE TO FACE	ANSI B16.10	SEAT	AIR	80PSI	SIZE: 6"-8"	FIG. No.:			
					WALL THICKNESS	API 600	BACK SEAT	HYDRO	2445PSI	DRAWN BY: F.J.		<b>GT900CSF8</b>		
					DESIGNED	API 600, ANSI B16.34				CHK'D & APR'D BY: E.C.		REV: 1		DWG No.:

NO.	DATE	DESCRIPTION	PRP'D	REV'D	APP'D
△	4/15/19	RELEASED	F.J.	E.C.	E.C.



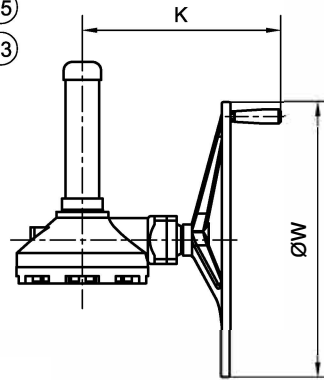
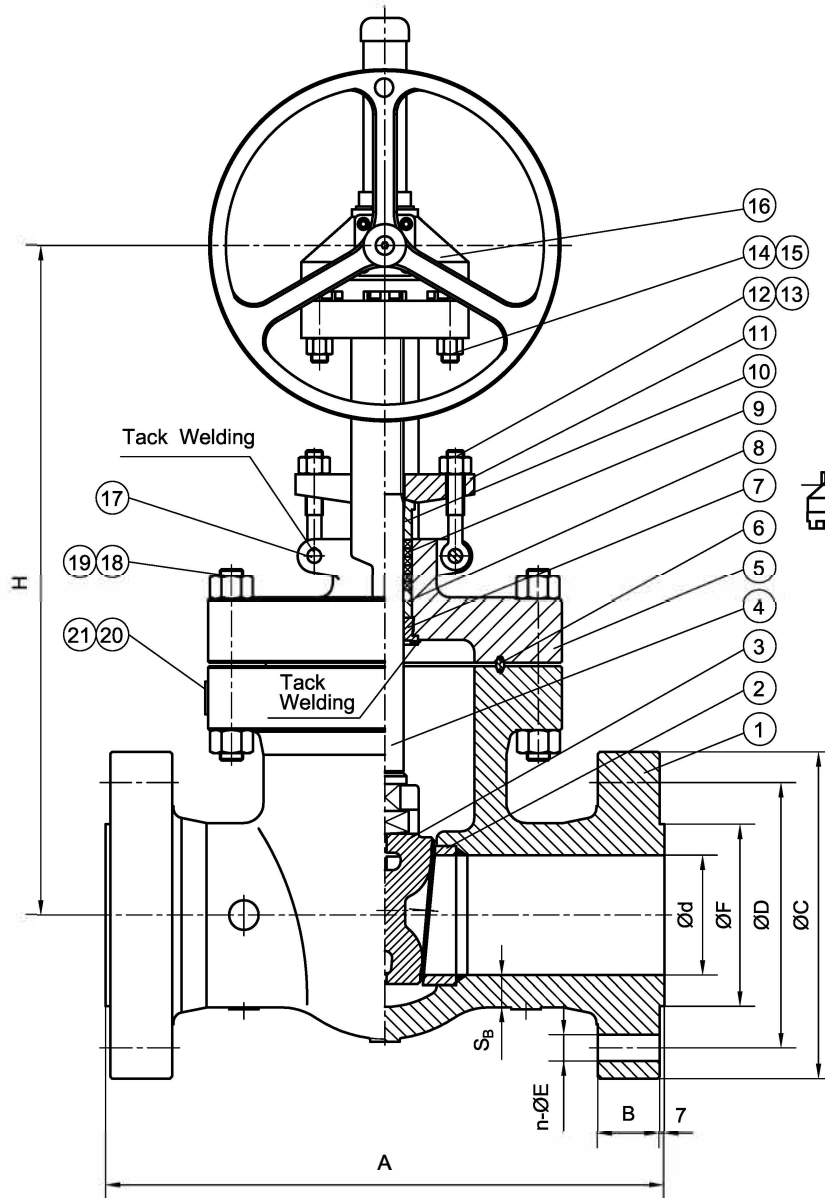

ITEM	NAME	MATERIAL
1	BODY	ASTM A216-WCB
2	SEAT	ASTM A105N+STL
3	FLEXIBLE WEDGE	ASTM A216-WCB+13%Cr
4	STEM	ASTM A182-F6a
5	BONNET	ASTM A216-WCB
6	RTJ GASKET	AISI 1008
7	BACKSEAT	ASTM A276-420
8	PACKING SPACER	ASTM A276-410
9	PACKING	INCONEL600+GRAPHITE
10	GLAND	ASTM A276-410
11	GLAND FLANGE	ASTM A216-WCB
12	EYE BOLT	ASTM A193-B7
13	NUT	ASTM A194-2H
14	BOLT	ASTM A193-B7
15	NUT	ASTM A194-2H
16	GEAR	ASTM A216-WCB
17	PIN	AISI 1035
18	BOLT	ASTM A193-B7
19	NUT	ASTM A194-2H
20	NAMEPLATE	ASTM A240-304
21	RIVET	ASTM A240-304

NOTE:

1. FLEXIBLE WEDGE
2. API 624 QUALIFIED

ITEM	FIG NO.	SIZE	UNIT	d	A	B	C	D	n	E	F	H	W	K	S <sub>b</sub>	Weight(lbs/kgs)
01	GT900CSF8	3"	mm	73	381	38.1	240	190.5	8	25	127	532	310	310	19.1	216/98
		3"	in	2.87	15.0	1.5	15.0	7.5	8	1	5.0	20.94	12.2	12.2	0.75	

Toll Free 800.582.5837 Local 310.605.0090

Here at J.J. Valve, we utilize a wide variety of products to meet your needs when it comes to Industrial valves.

TITLE: CAST STEEL GATE VALVE  
CLASS 900- API TRIM 8 - RF - GEAR OPERATED

MARKING SYSTEM	MSS-SP-25	INSPECTION & TEST: API 598	MATERIAL: ASTM A216 WCB	UNITS: Inch, mm
DIM.OF FLANGE	ANSI B16.5	SHELL HYDRO 3350PSI	CLASS: 900	DATE: 4/15/19
FACE TO FACE	ANSI B16.10	SEAT AIR 80PSI	SIZE: 3"	SCALE: N.T.S.
WALL THICKNESS	API 600	BACKSEAT HYDRO 2445PSI	DRAWN BY: F.J.	FIG. No.: GT900CSF8 GO
DESIGNED	API 600, ANSI B16.34		CHK'D & APR'D BY: E.C.	REV: 1
NO.	DATE	DESCRIPTION	PRP'D	REV'D
4/15/19	RELEASED	F.J.	E.C.	E.C.

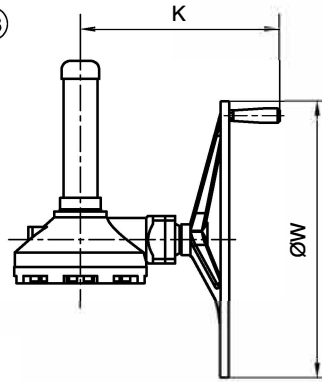
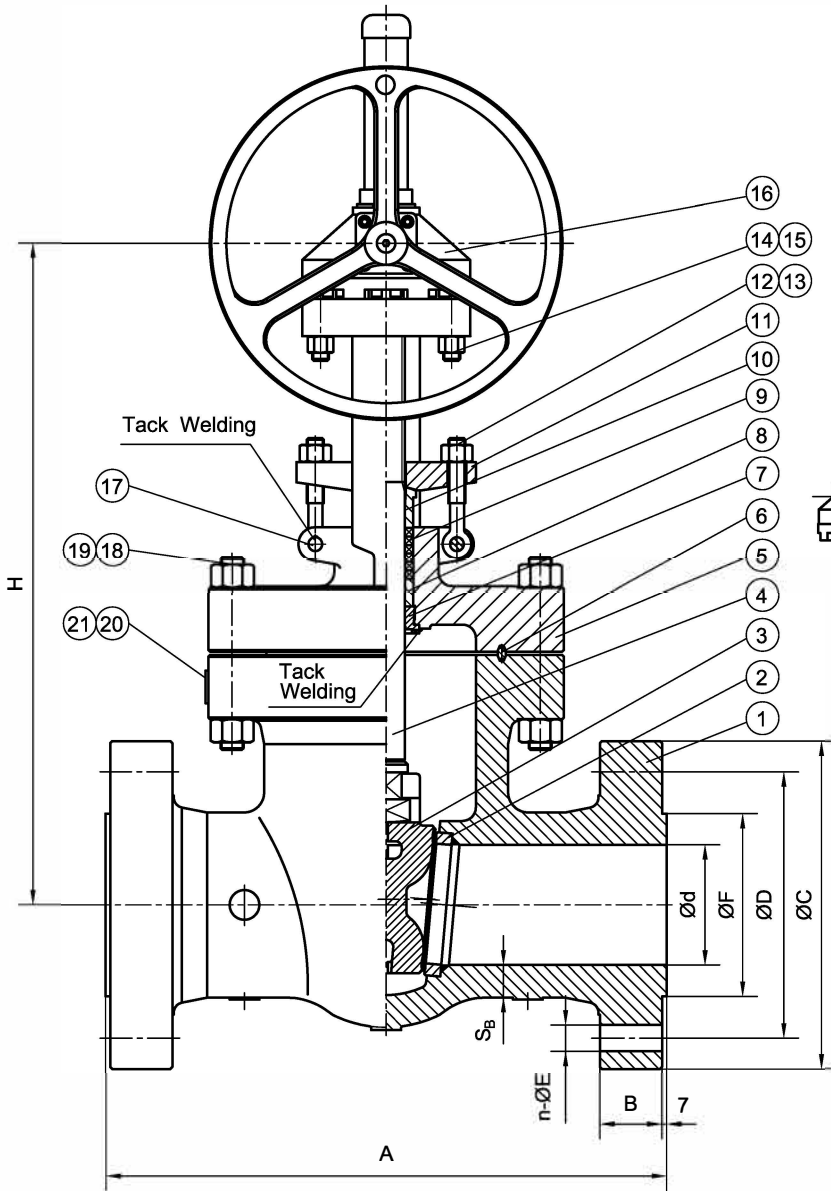

ITEM	NAME	MATERIAL
1	BODY	ASTM A216-WCB
2	SEAT	ASTM A105N+STL
3	FLEXIBLE WEDGE	ASTM A216-WCB+13%Cr
4	STEM	ASTM A182-F6a
5	BONNET	ASTM A216-WCB
6	RTJ GASKET	AISI 1008
7	BACKSEAT	ASTM A276-420
8	PACKING SPACER	ASTM A276-410
9	PACKING	INCONEL600+GRAPHITE
10	GLAND	ASTM A276-410
11	GLAND FLANGE	ASTM A216-WCB
12	EYE BOLT	ASTM A193-B7
13	NUT	ASTM A194-2H
14	BOLT	ASTM A193-B7
15	NUT	ASTM A194-2H
16	GEAR	ASTM A216-WCB
17	PIN	AISI 1035
18	BOLT	ASTM A193-B7
19	NUT	ASTM A194-2H
20	NAMEPLATE	ASTM A240-304
21	RIVET	ASTM A240-304

NOTE:

1. FLEXIBLE WEDGE
2. API 624 QUALIFIED

ITEM	FIG NO.	SIZE	UNIT	d	A	B	C	D	n	E	F	H	W	K	S <sub>B</sub>	Weight(lbs/kgs)
01	GT900CSF8	4"	mm	99	457	44.5	290	235	8	32	157.2	550	310	310	21.3	342/155
		4"	in	3.9	18.0	1.75	11.5	9.25	8	1-1/4	6.19	21.65	12.2	12.2	0.84	



**J.J. VALVE**

Toll Free 800.582.5837 Local 310.605.0090

Here at J.J. Valve, we utilize a wide variety of products to meet your needs when it comes to industrial valves.

TITLE:		CAST STEEL GATE VALVE	
		CLASS 900- API TRIM 8 - RF - GEAR OPERATED	
MATERIAL:	ASTM A216 WCB	UNITS:	Inch, mm
CLASS:	900	DATE:	4/15/19
SCALE:	N.T.S.	FIG. No.:	
SIZE:	4"	DRAWN BY:	F.J.
		<b>GT900CSF8GO</b>	
CHK'D & APR'D BY:	E.C.	REV:	1
		DWG No.:	

NO.	DATE	DESCRIPTION	PRP'D	REV'D	APP'D	DESIGNED	MARKING SYSTEM	MSS-SP-25	INSPECTION & TEST:	API 598	MATERIAL:	ASTM A216 WCB	UNITS:	Inch, mm				
							DIM.OF FLANGE	ANSI B16.5	SHELL	HYDRO	3350PSI	CLASS:	900	DATE:	4/15/19	SCALE:	N.T.S.	
							FACE TO FACE	ANSI B16.10	SEAT	AIR	80PSI	SIZE:	4"	FIG. No.:				
							WALL THICKNESS	API 600	BACK SEAT	HYDRO	2445PSI	DRAWN BY:	F.J.					
							DESIGNED	API 600, ANSI B16.34				CHK'D & APR'D BY:	E.C.	REV:	1	DWG No.:		

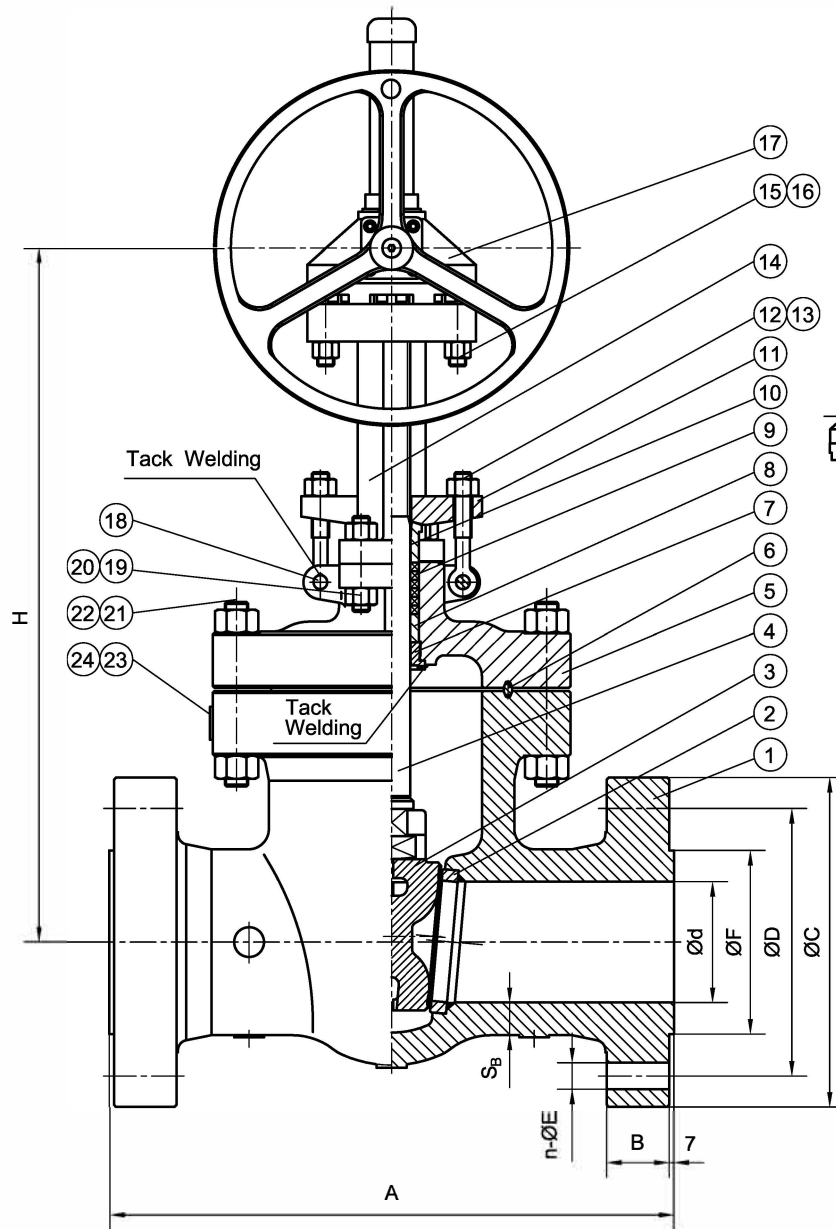

ITEM	NAME	MATERIAL
1	BODY	ASTM A216-WCB
2	SEAT	ASTM A105N+STL
3	FLEXIBLE WEDGE	ASTM A216-WCB+13%Cr
4	STEM	ASTM A182-F6a
5	BONNET	ASTM A216-WCB
6	RTJ GASKET	AISI 1008
7	BACKSEAT	ASTM A276-420
8	PACKING SPACER	ASTM A276-410
9	PACKING	INCONEL600+GRAPHITE
10	GLAND	ASTM A276-410
11	GLAND FLANGE	ASTM A216-WCB
12	EYE BOLT	ASTM A193-B7
13	NUT	ASTM A194-2H
14	YOKE	ASTM A216-WCB
15	BOLT	ASTM A193-B7
16	NUT	ASTM A194-2H
17	GEAR	ASTM A216-WCB
18	PIN	AISI 1035
19	BOLT	ASTM A193-B7
20	NUT	ASTM A194-2H
21	BOLT	ASTM A193-B7
22	NUT	ASTM A194-2H
23	NAMEPLATE	ASTM A240-304
24	RIVET	ASTM A240-304

NOTE:

1. FLEXIBLE WEDGE
2. API 624 QUALIFIED

ITEM	FIG NO.	SIZE	UNIT	d	A	B	C	D	n	E	F	H	W	K	S <sub>B</sub>	Weight(lbs/kgs)
01	GT900CSF8	6"	mm	146	610	55.6	380	317.5	12	32	215.9	770	460	345	26.2	783/355
		6"	in	5.75	24.0	2.19	15.0	12.5	12	1-1/4	8.5	30.3	18.1	13.58	1.03	
02	GT900CSF8	8"	mm	191	737	63.5	470	393.7	12	38	269.9	892	610	420	31.8	1367/620
		8"	in	7.52	29.0	2.5	18.5	15.5	12	1-1/2	10.62	35.1	24.0	16.53	1.25	

				MARKING SYSTEM	MSS-SP-25	INSPECTION & TEST: API 598			MATERIAL: ASTM A216 WCB			UNITS: Inch, mm		
				DIM.OF FLANGE	ANSI B16.5	SHELL	HYDRO	3350PSI	CLASS: 900		DATE: 4/15/19	SCALE: N.T.S.		
				FACE TO FACE	ANSI B16.10	SEAT	AIR	80PSI	SIZE: 6"-8"		FIG. No.: GT900CSF8GO			
				WALL THICKNESS	API 600	BACK SEAT	HYDRO	2445PSI	DRAWN BY: F.J.					
4/15/19 RELEASED F.J. E.C. E.C. NO. DATE DESCRIPTION PRP'D REV'D APP'D				DESIGNED	API 600, ANSI B16.34			CHK'D & APR'D BY: E.C.		REV: 1	DWG No.:			

Toll Free 800.582.5837 Local 310.605.0090

Here at J.J. Valve, we utilize a wide variety of products to meet your needs when it comes to industrial valves.

TITLE: CAST STEEL GATE VALVE  
CLASS 900- API TRIM 8 - RF - GEAR OPERATED

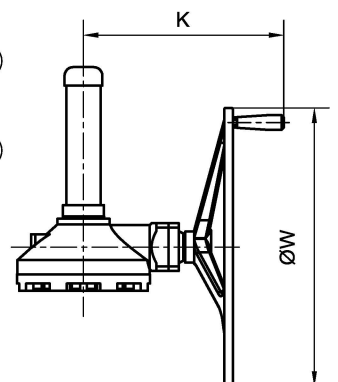
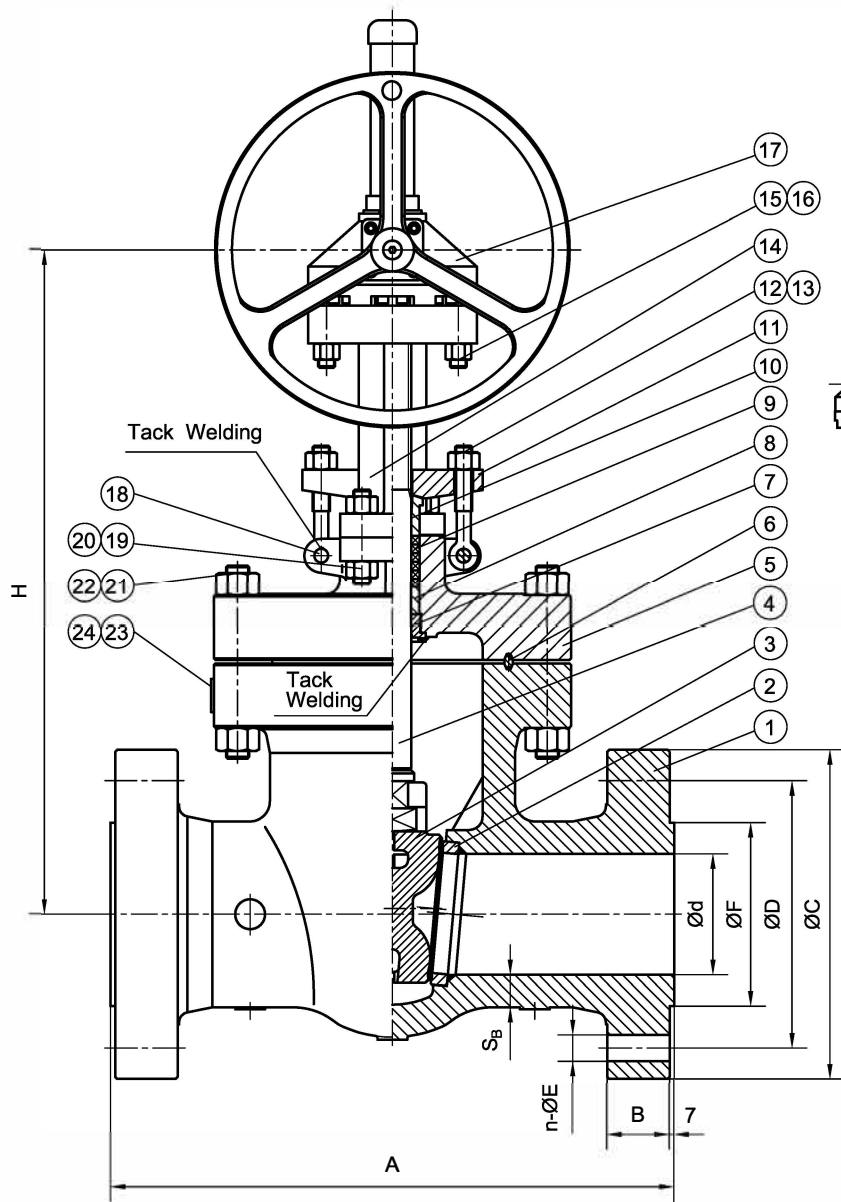

ITEM	NAME	MATERIAL
1	BODY	ASTM A216-WCB
2	SEAT	ASTM A105N+STL
3	FLEXIBLE WEDGE	ASTM A216-WCB+13%Cr
4	STEM	ASTM A182-F6a
5	BONNET	ASTM A216-WCB
6	RTJ GASKET	AISI 1008
7	BACKSEAT	ASTM A276-420
8	PACKING SPACER	ASTM A276-410
9	PACKING	INCONEL600+GRAPHITE
10	GLAND	ASTM A276-410
11	GLAND FLANGE	ASTM A216-WCB
12	EYE BOLT	ASTM A193-B7
13	NUT	ASTM A194-2H
14	YOKE	ASTM A216-WCB
15	BOLT	ASTM A193-B7
16	NUT	ASTM A194-2H
17	GEAR	ASTM A216-WCB
18	PIN	AISI 1035
19	BOLT	ASTM A193-B7
20	NUT	ASTM A194-2H
21	BOLT	ASTM A193-B7
22	NUT	ASTM A194-2H
23	NAMEPLATE	ASTM A240-304
24	RIVET	ASTM A240-304

NOTE:  
 1. FLEXIBLE WEDGE  
 2. API 624 QUALIFIED

ITEM	FIG NO.	SIZE	UNIT	d	A	B	C	D	n	E	F	H	W	K	S <sub>b</sub>	Weight(lbs/kgs)
01	GT900CSF8	10"	mm	238	838	69.9	545	469.9	16	38	323.8	1032	610	420	36.6	2216/1005
		10"	in	9.37	33.0	2.75	21.5	18.5	16	1-1/2	12.75	40.63	24.0	16.53	1.44	



**J.J. VALVE**  
 Toll Free 800.582.5837 Local 310.605.0090

Here at J.J. Valves, we utilize a wide variety of products to meet your needs when it comes to industrial valves.

TITLE:				CAST STEEL GATE VALVE			
				CLASS 900- API TRIM 8 - RF - GEAR OPERATED			
MARKING SYSTEM		MSS-SP-25		INSPECTION & TEST: API 598		MATERIAL: ASTM A216 WCB	
DIM.OF FLANGE		ANSI B16.5		SHELL HYDRO		3350PSI	
FACE TO FACE		ANSI B16.10		SEAT AIR		80PSI	
WALL THICKNESS		API 600		BACK SEAT HYDRO		2445PSI	
NO.		DATE		DESIGNED		CHK'D & APR'D BY:	
4/15/19		RELEASED		API 600, ANSI B16.34		E.C.	
PRP'D		REV'D		APP'D		REV: 1	
F.J.		E.C.		E.C.		DRAWN BY: F.J.	
						<b>GT900CSF8GO</b>	
						DWG No.:	

NO.	DATE	DESCRIPTION	PRP'D	REV'D	APP'D
1	4/15/19	RELEASED	F.J.	E.C.	E.C.



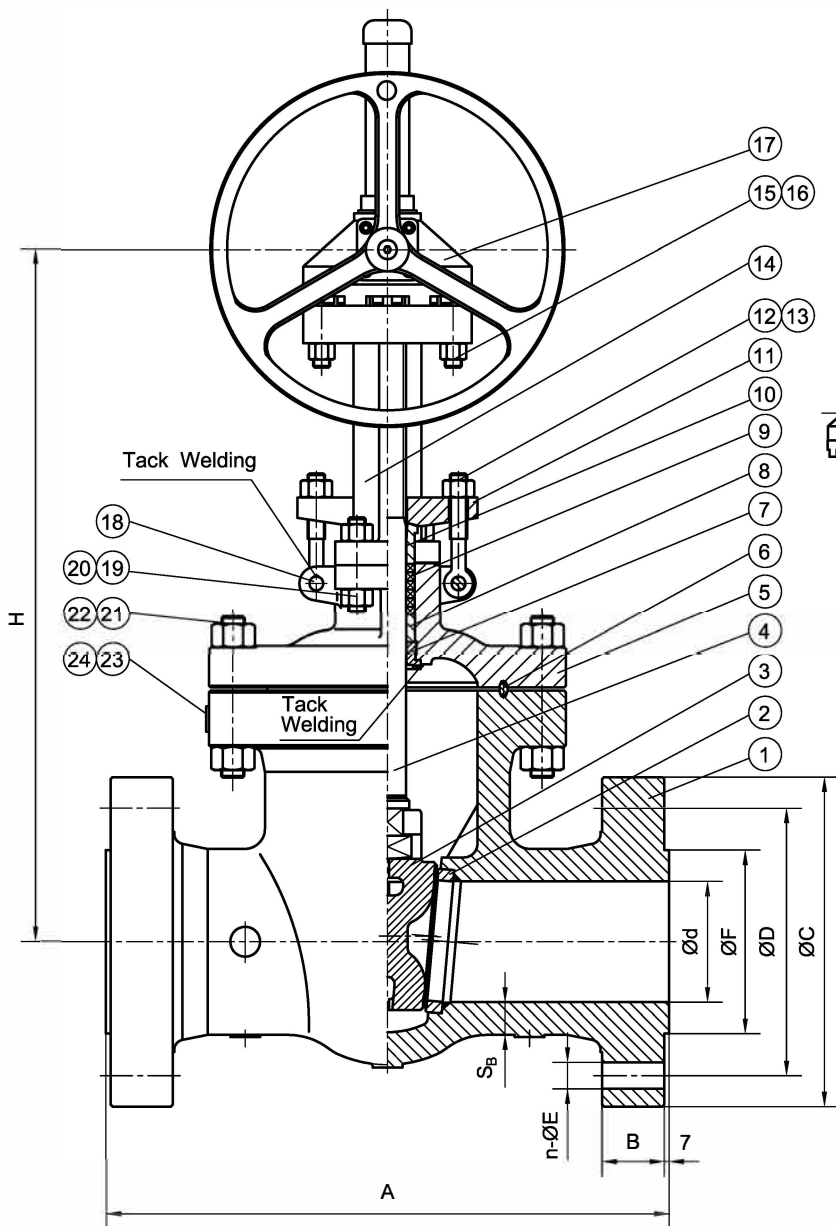

ITEM	NAME	MATERIAL
1	BODY	ASTM A216-WCB
2	SEAT	ASTM A105N+STL
3	FLEXIBLE WEDGE	ASTM A216-WCB+13%Cr
4	STEM	ASTM A182-F6a
5	BONNET	ASTM A216-WCB
6	RTJ GASKET	AISI 1008
7	BACKSEAT	ASTM A276-420
8	PACKING SPACER	ASTM A276-410
9	PACKING	INCONEL600+GRAPHITE
10	GLAND	ASTM A276-410
11	GLAND FLANGE	ASTM A216-WCB
12	EYE BOLT	ASTM A193-B7
13	NUT	ASTM A194-2H
14	YOKE	ASTM A216-WCB
15	BOLT	ASTM A193-B7
16	NUT	ASTM A194-2H
17	GEAR	ASTM A216-WCB
18	PIN	AISI 1035
19	BOLT	ASTM A193-B7
20	NUT	ASTM A194-2H
21	BOLT	ASTM A193-B7
22	NUT	ASTM A194-2H
23	NAMEPLATE	ASTM A240-304
24	RIVET	ASTM A240-304

NOTE:

1. FLEXIBLE WEDGE
2. API 624 QUALIFIED

ITEM	FIG NO.	SIZE	UNIT	d	A	B	C	D	n	E	F	H	W	K	S <sub>b</sub>	Weight(lbs/kgs)
01	GT900CSF8	12"	mm	282	965	79.4	610	533.4	20	38	381	1165	710	505	42.2	2998/1360
		12"	in	11.1	38.0	3.13	24.0	21.0	20	1-1/2	15.0	45.87	27.95	19.88	1.66	
02	GT900CSF8	14"	mm	311.2	1039	85.8	640	558.8	20	41	412.8	1284	710	505	46	4969/2254
		14"	in	12.25	40.91	3.38	25.25	22.0	20	1-5/8	16.25	50.55	27.95	19.88	1.81	
03	GT900CSF8	16"	mm	355.6	1140	88.9	705	616	20	45	469.9	1386	800	605	52.3	6283/2850
		16"	in	14.0	44.88	3.50	27.75	24.25	20	1-3/4	18.5	54.57	31.5	23.82	2.06	

**J.J. VALVE**  
Toll Free 800.582.5837 Local 310.605.0090  
Here at J.J. Valve, we utilize a wide variety of products to meet your needs when it comes to industrial valves.

TITLE:		CAST STEEL GATE VALVE	
		CLASS 900- API TRIM 8 - RF - GEAR OPERATED	
MATERIAL:	ASTM A216 WCB	UNITS:	Inch, mm
CLASS:	900	DATE:	4/15/19
FACE TO FACE:	ANSI B16.10	SCALE:	N.T.S.
SIZE:	12"-16"	FIG. No.:	
WALL THICKNESS:	API 600	DRAWN BY: F.J.	
BACK SEAT:	HYDRO	REV: 1	
DESIGNED:	API 600, ANSI B16.34	DWG No.:	

NO.	DATE	DESCRIPTION	PRP'D	REV'D	APP'D
4/15/19	RELEASED		F.J.	E.C.	E.C.

MARKING SYSTEM	MSS-SP-25	INSPECTION & TEST:	API 598
DIM.OF FLANGE	ANSI B16.5	SHELL	HYDRO 3350PSI
FACE TO FACE	ANSI B16.10	SEAT	AIR 80PSI
WALL THICKNESS	API 600	BACK SEAT	HYDRO 2445PSI
DESIGNED	API 600, ANSI B16.34		