

Steamco Valves

SIZE	d	C	D	L	nxφ	t	L	WGT (lbs)
2"	2.19	4.75	6.00	4.00	4 x .75	0.63	4.00	32
2-1/2"	2.50	5.50	7.00	4.25	4 x .75	0.69	4.25	38
3"	3.00	6.00	7.50	4.75	4 x .75	0.75	4.75	54
4"	4.00	7.50	9.00	5.75	8 x .75	0.94	5.75	88
6"	6.00	9.50	11.00	7.00	8 x .88	1.00	7.00	158

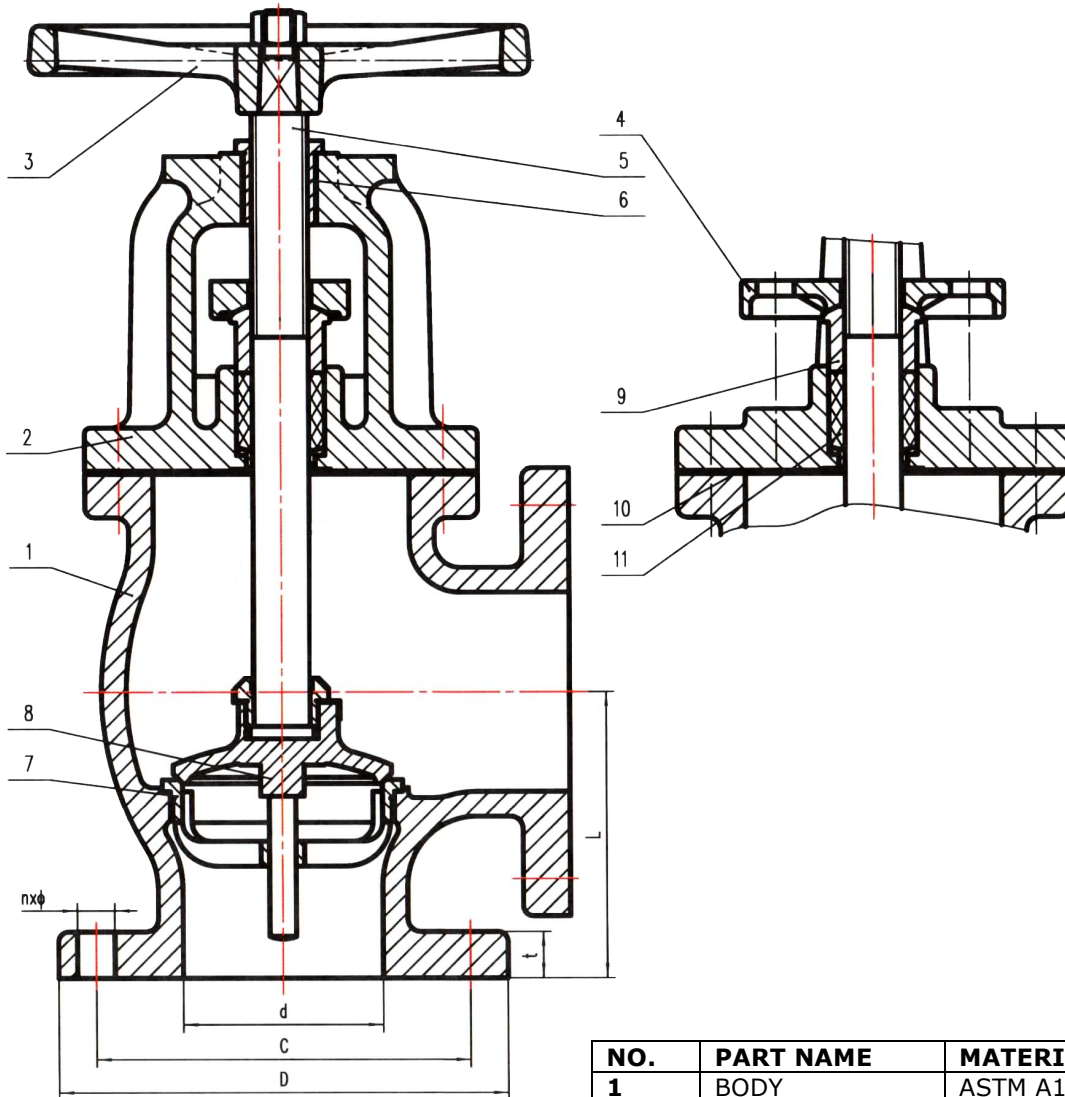

APPLICABLE STANDARDS

BASIC DESIGN: MSS SP-85, ASME B16.34
 FLANGE DIMENSIONS: ASME B16.1

NO.	PART NAME	MATERIAL
1	BODY	ASTM A126 B
2	BONNET	ASTM A126 B
3	HANDWHEEL	ASTM A536 65-45-12
4	GLAND FLANGE	ASTM A536 65-45-12
5	STEM	ASTM B584 C86400
6	STEM NUT	ASTM B584 C86400
7	BODY SEAT RING	ASTM B584 C84400
8	DISC	ASTM B584 C84400
9	GLAND	ASTM B16 C36000
10	GASKET	GRAPHITE
11	PACKING	GRAPHITE

Steamco Fig. 126ANG

CLASS 125 IRON BODY ANGLE VALVE