

Steamco Valves

APPLICABLE STANDARDS

BASIC DESIGN: MSS SP-70, ASME B16.34

FLANGE DIMENSIONS: ASME B16.1

FACE TO FACE DIMENSIONS: ASME B16.10

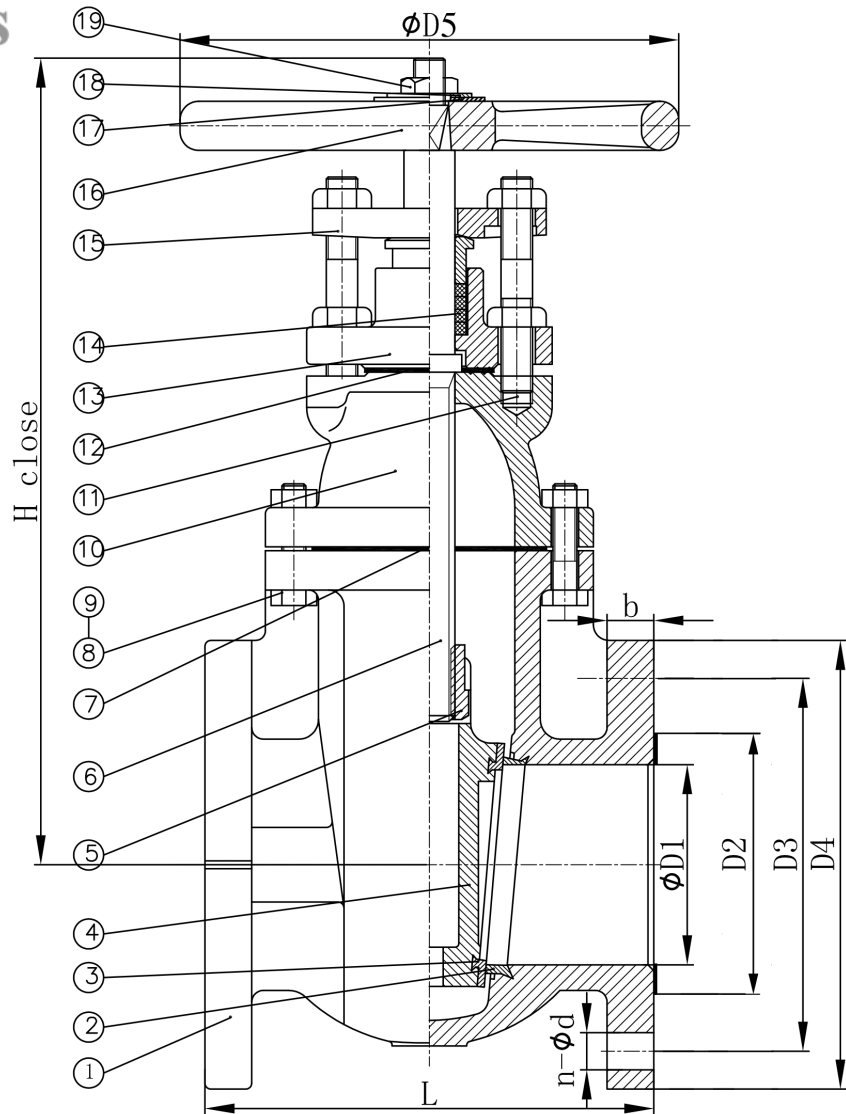

SIZE	2"	2-1/2"	3"	4"	5"	6"	8"
L	8-1/2	9-1/2	11-1/8	12	15	15-7/8	16-1/2
D1	2	2-1/2	3	4	5	6	8
D2	3.62	4.12	5.00	6.19	7.31	8.50	10.62
D3	5.00	5.88	6.62	7.88	9.25	10.62	13.00
b	7/8	1	1-1/6	1-1/4	1-3/8	1-7/16	1-5/8
n- Ød	8 x 3/4	8 x 7/8	8 x 7/8	8 x 7/8	8 x 7/8	12 x 7/8	12 x 1
D4	6.5	7.50	8.25	10.00	11.00	12.50	15.00
H	12 1/2	15	16 1/2	18 1/2	20 3/4	24	28 1/2
WEIGHT (lbs)	59	75	102	170	217	295	430

NO.	PART NAME	MATEREIAL	STANDARD	NO.	PART NAME	MATERIAL	STANDARD
1	BODY	CAST IRON	ASTM A126 B	10	BONNET	CAST IRON	ASTM B126 B
2	SEAT RING	CAST BRONZE	ASTM B62	11	BOLTS	STEEL	ASTM A307 B
3	WEDGE FACE RING	CAST BRONZE	ASTM B62	12	GASKET	GRAPHITE	COMMERCIAL
4	WEDGE	CAST IRON	ASTM A126 B	13	STUFFING BOX	CAST IRON	ASTM A126 B
5	STEM BUSHING	CAST BRASS	ASTM B584	14	PACKING	GRAPHITE	COMMERCIAL
6	STEM	BRASS	ASTM B16	15	GLAND FOLLOWER	DUCTILE IRON	ASTM A536
7	GASKET	GRAPHITE	COMMERCIAL	16	HANDWHEEL	CAST IRON	ASTM A126 B
8	BOLTS	STEEL	ASTM A307 B	17	NAME PLATE	ALUMINUM	COMMERCIAL
9	NUTS	STEEL	ASTM A307 B	18	WASHER	STEEL	ASTM A307 B
				19	NUT	STEEL	ASTM A307 B

Steamco Fig. 250B

CLASS 250 NRS GATE VALVE