

Steamco Valves

APPLICABLE STANDARDS
 BASIC DESIGN: ASME B16.34
 FLANGE DIMENSIONS: ASME B16.5
 TEST AND INSPECTION API 598

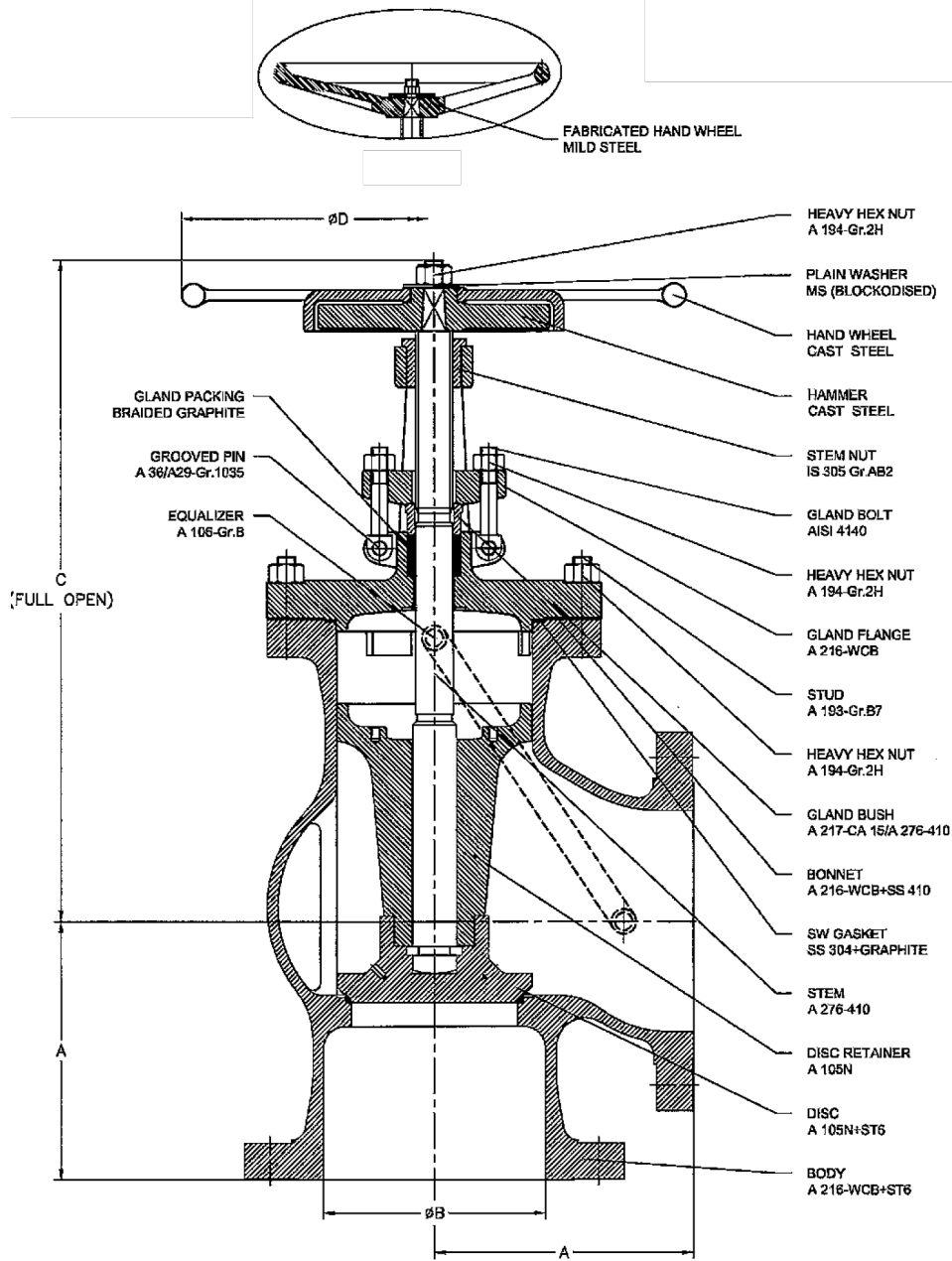

SIZE	A	ØB	C	ØD
4	7.00	4.00	16.30	14.00
5	7.88	5.00	20.00	18.00
6	8.75	6.00	21.80	20.00
8	11.00	8.00	25.60	20.00
10	12.25	10.00	31.50	20.00
12	14.00	12.00	42.30	27.20

TESTING PRESSURE		
# 300	MEDIUM	PSI
SHELL TEST	WATER	1125
BACKSEAT TEST	WATER	825
SEAT TEST	WATER	825

Steamco Fig. 303ANR

CLASS 300 CS ANGLE NON RETURN VALVE